

EVS-3000 USER

Intel® Core™ i9/i7/i5/i3 Processor (14th Gen)
Expandable AI Computing System with MXM Graphics

Manual

Record of Revision

Version	Date	Page	Description	Remark
1.00	2024/12/18	All	Official Release	

Disclaimer

This manual is released by Vecow Co., Ltd. for reference purpose only. All product offerings and specifications are subject to change without prior notice. Vecow Co., Ltd. is under no legal commitment to the details of this document. Vecow shall not be liable for direct, indirect, special, incidental, or consequential damages arising out of the use of this document, the products, or any third party infringements, which may result from such use.

Declaration of Conformity

FCC This equipment has been tested and found to comply with the limits for a Class A digital device, pursuant to part 15 of the FCC Rules. These limits are designed to provide reasonable protection against harmful interference when the equipment is operated in a commercial environment. This equipment generates, uses, and can radiate radio frequency energy, and if it is not installed and used in accordance with the instruction manual, it may cause harmful interference to radio communications. Operation of this equipment in a residential area is likely to cause harmful interference in which case the user will be required to correct the interference at his own expense.

CE The products described in this manual comply with all applicable European Union (CE) directives if it has a CE marking. For computer systems to remain CE compliant, only CE-compliant parts may be used. Maintaining CE compliance also requires proper cable and cabling techniques.

Copyright and Trademarks

This document contains proprietary information protected by copyright. No part of this publication may be reproduced in any form or by any means, electric, photocopying, recording or otherwise, without prior written authorization by Vecow Co., Ltd. The rights of all the brand names, product names, and trademarks belong to their respective owners.

Order Information

Part Number	Description
EVS-3400	EVS-3000, 2 2.5GigE LAN , 1 PCIe x8, 3 PCIe x4, 4 USB 3.2 Type-A, 1 USB 3.2 Type-C, 2 COM, 1 SIM, 32 Isolated DIO, Fanless
EVS-3300	EVS-3000, 2 2.5GigE LAN , 1 PCIe x8, 2 PCIe x4, 4 USB 3.2 Type-A, 1 USB 3.2 Type-C, 2 COM, 1 SIM, 32 Isolated DIO, Fanless
EVS-3200	EVS-3000, 2 2.5GigE LAN , 1 PCIe x8, 1 PCIe x4, 4 USB 3.2 Type-A, 1 USB 3.2 Type-C, 2 COM, 1 SIM, 32 Isolated DIO, Fanless
EVS-3100	EVS-3000, 2 2.5GigE LAN, 1 PCIe x8, 4 USB 3.2 Type-A, 1 USB 3.2 Type-C, 2 COM, 1 SIM, 32 Isolated DIO, Fanless
EVS-3400F	EVS-3000, 2 2.5GigE LAN , 1 PCIe x8, 3 PCIe x4, 4 USB 3.2 Type-A, 1 USB 3.2 Type-C, 2 COM, 1 SIM, 32 Isolated DIO, With System Fan
EVS-3300F	EVS-3000, 2 2.5GigE LAN , 1 PCIe x8, 2 PCIe x4, 4 USB 3.2 Type-A, 1 USB 3.2 Type-C, 2 COM, 1 SIM, 32 Isolated DIO, With System Fan
EVS-3200F	EVS-3000, 2 2.5GigE LAN , 1 PCIe x8, 1 PCIe x4, 4 USB 3.2 Type-A, 1 USB 3.2 Type-C, 2 COM, 1 SIM, 32 Isolated DIO, With System Fan
EVS-3100F	EVS-3000, 2 2.5GigE LAN, 1 PCIe x8, 4 USB 3.2 Type-A, 1 USB 3.2 Type-C, 2 COM, 1 SIM, 32 Isolated DIO, With System Fan

CPU List

Series	CPU	Cores	GHz	TDP(W)	CPU	Cores	GHz	TDP(W)
Intel® Core™	i9-14900	24	5.8	65	i9-14900T	24	5.5	35
	i7-14700	20	5.4		i7-14700T	20	5.2	
	i5-14500	14	5		i5-14500T	14	4.8	
	i3-14100	4	4.7		i3-14100T	4	4.4	
	i9-13900E	24	5.2		i9-13900TE	24	5	
	i7-13700E	16	5.1		i7-13700TE	16	4.8	
	i5-13500E	14	4.6		i5-13500TE	14	4.5	
	i3-13100E	4	4.4		i3-13100TE	4	4.1	
	i9-12900E	16	5		i9-12900TE	16	4.8	
	i7-12700E	12	4.8		i7-12700TE	12	4.7	
	i5-12500E	6	4.5		i5-12500TE	6	4.3	
	i3-12100E	4	4.2		i3-12100TE	4	4	

Order Accessories

Part Number	Description
DDR5 48G	Certified DDR5 48GB 5600MHz RAM
DDR5 32G	Certified DDR5 32GB 5600/4800MHz RAM
DDR5 24G	Certified DDR5 24GB 5600MHz RAM
DDR5 16G	Certified DDR5 16GB 5600/4800MHz RAM
DDR5 8G	Certified DDR5 8GB 5600/4800MHz RAM
PWA-160WB-WT	160W, 24V, 85V AC to 264V AC Power Adaptor with 3-pin Terminal Block (7.62mm pitch), Wide Temperature -30°C to +70°C
PWA-180WB	180W, 24V, 90V AC to 264V AC Power Adapter with 3-pin Terminal Block (7.62mm pitch)
PWA-280WB-WT	280W, 24V, 85V AC to 264V AC Power Adapter with 3-pin Terminal Block (7.62mm pitch), Wide Temperature -30°C to +70°C *Recommended when enable turbo mode (35W CPU), without expansion card
PWA-330WB	330W, 24V, 90V AC to 264V AC Power Adapter with 3-pin Terminal Block (7.62mm pitch) *Recommended when enable turbo mode (65W CPU), without expansion card
PWS-480W-WT	480W, 24V, 90V AC to 305V AC Power Supply, Wide-Temp, IP65
VESA Mount	VESA Mounting Kit
DIN-RAIL	DIN Rail Kit
Rack Mount	2U Rackmount Kit
TMK2-20P-100	Terminal Block 20-pin to Terminal Block 20-pin Cable, 100cm
TMK2-20P-500	Terminal Block 20-pin to Terminal Block 20-pin Cable, 500cm
TMB-TMBK-20P	Terminal Board with One 20-pin Terminal Block Connector and DIN-Rail Mounting
M.2 Storage Module	M.2 Key M Storage Module
5G Module	5G Module with Antenna
4G Module	4G/GPS Module with Antenna
WiFi & Bluetooth	WiFi & Bluetooth Module with Antenna

Table of Contents

CHAPTER 1	GENERAL INTRODUCTION	1
1.1	Overview	1
1.2	Features	2
1.3	Product Specification	3
1.3.1	Specifications of EVS-3400	3
1.3.2	Specifications of EVS-3300	5
1.3.3	Specifications of EVS-3200	7
1.3.4	Specifications of EVS-3100	9
1.3.5	Specifications of EVS-3400F	11
1.3.6	Specifications of EVS-3300F	13
1.3.7	Specifications of EVS-3200F	15
1.3.8	Specifications of EVS-3100F	17
1.4	Supported CPU List	19
1.5	Mechanical Dimension	20
1.5.1	Dimensions of EVS-3400	20
1.5.2	Dimensions of EVS-3300	20
1.5.3	Dimensions of EVS-3200	21
1.5.4	Dimensions of EVS-3100	21
1.5.5	Dimensions of EVS-3400F	22
1.5.6	Dimensions of EVS-3300F	22
1.5.7	Dimensions of EVS-3200F	23
1.5.8	Dimensions of EVS-3100F	23
CHAPTER 2	GETTING TO KNOW YOUR EVS-3000	24
2.1	Packing List of EVS-3000/3000F	24
2.1.1	Packing List of EVS-3100(F)/3200(F)	24
2.1.2	Packing List of EVS-3300(F)/3400(F)	25
2.2	Front Panel I/O & Functions	26
2.3	Rear Panel I/O & Functions	34
2.4	Main Board Expansion Connectors	39
2.5	Main Board Jumper Settings	55
2.6	Ignition Control	60

CHAPTER 3	SYSTEM SETUP	63
3.1	How to Open Your EVS-3000	63
3.2	Installing CPU	65
3.3	Installing DDR5 SO-DIMM Modules	71
3.4	Installing M.2 (Key B/E/M)	73
3.5	Installing SSD/HDD	80
3.6	PCIe Card	84
3.7	SIM Card	86
3.8	Installing Antenna Cable	87
3.9	Mounting Your EVS-3000	88
CHAPTER 4	BIOS SETIP	90
4.1	BIOS Settings	90
4.2	Main	91
4.3	Advanced	92
4.4	Chipset Menu	100
4.5	Security Menu	105
4.6	Boot Menu	106
4.7	Save & Exit	107
APPENDIX A	: Isolated DIO Guide	108
APPENDIX B	: Software Functions	112
APPENDIX C	: RAID Functions	115
APPENDIX D	: Power Consumption	121
APPENDIX E	: Supported Memory & Storage List	129
APPENDIX F	: Setting up Allxon OOB	131

1

GENERAL INTRODUCTION

1.1 Overview

The Vecow EVS-3000 series is a new line of AI computing systems powered by Intel® Core™ i9/i7/i5/i3 processor (14th Gen) with integrated MXM graphics. Designed to advance edge AI applications, the EVS-3000 series delivers high-performance computing capability, exceptional scalability, and robust design, ideal for autonomous robotics, public security, machine vision, and other Edge AI applications.

Featuring Intel® Core™ processors (14th Gen), the EVS-3000 series offers up to 24 cores, 32 threads, and a clock speeds reaching up to 6 GHz. With support for up to a 115W MXM GPU and up to 4 PCIe slots, this series is equipped for additional PCIe GPU integration, providing outstanding CPU and GPU computing power for advanced AI processing at the edge.

The EVS-3000 series is available in both fanless and fan system configurations—EVS-3400(F), EVS-3300(F), EVS-3200(F), and EVS-3100(F)—to offer flexible solutions that meet diverse operational requirements and cost considerations for embedded applications. For example, the EVS-3400 supports up to 4 PCIe expansion slots and includes versatile I/O options such as M12 PoE+, 10G PoE+, 10G LAN, and USB. It also integrates advanced connectivity features like USB 3.2 Gen 2x2, an M.2 Key M SSD tray, and 2.5G LAN.

1.2 Features

- Workstation-grade Platform: Intel® Core™ i9/i7/i5/i3 Processor running with Intel® R680E PCH supports max 65W TDP CPU
- Up to 115W NVIDIA® Quadro®/GeForce® MXM graphics card
- 200W power budget for multiple AI computing GPUs
- Up to 2 Front-access M.2 and 2 2.5" SSD Tray; 1 SIM Socket for wireless network
- USB 3.2 Gen 2x2 offers max data transfer speeds of 20Gbps
- DC 9V to 55V wide range power input with Software Ignition Control
- Remote devices Out-of-Band management functions powered by Allxon
- Fanless operation in temperatures from -25°C to 55°C

1.3 Product Specification

1.3.1 Specifications of EVS-3400

System	
Processor	<ul style="list-style-type: none"> • 24-core Intel® Core™ i9/i7/i5/i3 Processor (14th gen, Raptor Lake-S Refresh) • 24-core 13th Gen Intel® Core™ i9/i7/i5/i3 Processor (Raptor Lake-S) • 16-core 12th Gen Intel® Core™ i9/i7/i5/i3 Processor (Alder Lake-S)
Chipset	Intel® R680E
BIOS	AMI
SIO	IT8786E
Memory	2 DDR5 5600MHz SO-DIMM, up to 96GB (ECC/Non-ECC)
OS	Windows 11, Windows 10, Linux
I/O Interface	
Serial	2 COM RS-232/422/485 (ESD 8kV)
USB	<ul style="list-style-type: none"> • 4 USB 3.2 Gen 2 Type A • 1 USB 3.2 Gen 2x2, USB Type-C supports max 20Gbps data transfer (15W, 5V/3A)
Isolated DIO	32 Isolated DIO : 16 DI, 16 DO
LED	Power, HDD, OOB
SIM Card	1 External SIM Card Socket for 5G/4G/LTE/GPRS/UMTS wireless network
Expansion	
PCIe	4 PCIe Slot : <ul style="list-style-type: none"> • 1 PCIe x16 Slot with x8 signal • 1 PCIe x8 Slot with x4 signal • 1 PCIe x16 Slot with x4 signal • 1 PCIe x8 Slot with x4 signal
M.2	<ul style="list-style-type: none"> • 1 M.2 Key B Socket (2280/3042/3052, PCIe/USB 3, default/SATA) • 1 M.2 Key E Socket (2230, PCIe/USB)
Graphics	
Graphics Processor	Intel® UHD Graphics 770/730 driven by Intel® X® Architecture
Interface	Up to 7 independent displays : <ul style="list-style-type: none"> • 2 HDMI 2.1 : Up to 4096 x 2304 @60Hz • 1 DP : Up to 3840 x 2160 @60Hz • 4 DP : Up to 7680 x 4320 @60Hz (By requested MXM)
Storage	
SATA	2 SATA III (6Gbps) support S/W RAID 0, 1 with 2 Front-access 2.5" SSD/HDD Tray
M.2	<ul style="list-style-type: none"> • 1 M.2 Key M Socket (2280, PCIe x4) • 2 Front-access M.2 Key M SSD Tray

Audio	
Audio Codec	Realtek® ALC888S-VD, 7.1 Channel HD Audio
Audio Interface	1 Mic-in, 1 Line-out
Ethernet	
LAN 1	Intel® I226 2.5GigE LAN supports TSN
LAN 2	Intel® I226 2.5GigE LAN supports TSN
Power	
Input Voltage	DC 9V to 55V
Power Interface	3-pin Terminal Block : V+, V-, Frame Ground
Ignition Control	16-mode Software Ignition Control
Remote Switch	3-pin Terminal Block : On, Off, IGN
Out-of-Band Management	
MCU	Nuvoton NUC980
Interface	OOB LAN, 10/100Mb Ethernet LAN, RJ45 Connector
Remote Management	Support Remote Power ON/OFF, Reset and Power Cycling
Others	
TPM	Infineon SLB9670 supports TPM 2.0, SPI Interface
Watchdog Timer	Reset : 1 to 255 sec./min. per step
Smart Management	Wake on LAN, PXE supported
HW Monitor	Monitoring temperature, voltages. Auto throttling control when CPU overheats.
Mechanical	
Dimension (W x D x H)	280 mm x 152 mm x 215 mm (11.02" x 5.98" x 8.46")
Weight	6.8 kg (14.99 lb)
Mounting	<ul style="list-style-type: none"> • Wall mount by mounting bracket • VESA Mount (Optional) • DIN Rail Mount (Optional) • Rackmount (Optional)
Environment	
Operating Temperature	35W TDP CPU : -25°C to 55°C (-13°F to 131°F) with air flow 65W TDP CPU : -25°C to 45°C (-13°F to 113°F) with air flow
Storage Temperature	-40°C to 85°C (-40°F to 185°F)
Humidity	5% to 95% humidity, non-condensing
Relative Humidity	95% @55°C
Shock	<ul style="list-style-type: none"> • IEC 60068-2-27 • SSD : 50G @wallmount, Half-sine, 11ms • MIL-STD-810G method 514.6, Category 4 (with PCIe Card)
Vibration	<ul style="list-style-type: none"> • IEC 60068-2-64 • SSD : 5Grms, 5Hz to 500Hz, 3 Axis • MIL-STD-810G method 516.6, Procedure I (with PCIe Card)
EMC	CE, FCC, ICES, EN50155, EN50121-3-2

1.3.2 Specifications of EVS-3300

System	
Processor	<ul style="list-style-type: none"> • 24-core Intel® Core™ i9/i7/i5/i3 Processor (14th gen, Raptor Lake-S Refresh) • 24-core 13th Gen Intel® Core™ i9/i7/i5/i3 Processor (Raptor Lake-S) • 16-core 12th Gen Intel® Core™ i9/i7/i5/i3 Processor (Alder Lake-S)
Chipset	Intel® R680E
BIOS	AMI
SIO	IT8786E
Memory	2 DDR5 5600MHz SO-DIMM, up to 96GB (ECC/Non-ECC)
OS	Windows 11, Windows 10, Linux
I/O Interface	
Serial	2 COM RS-232/422/485 (ESD 8kV)
USB	<ul style="list-style-type: none"> • 4 USB 3.2 Gen 2 Type A • 1 USB 3.2 Gen 2x2, USB Type-C supports max 20Gbps data transfer (15W, 5V/3A)
Isolated DIO	32 Isolated DIO : 16 DI, 16 DO
LED	Power, HDD, OOB
SIM Card	1 External SIM Card Socket for 5G/4G/LTE/GPRS/UMTS wireless network
Expansion	
PCIe	3 PCIe Slot : <ul style="list-style-type: none"> • 1 PCIe x16 Slot with x8 signal • 1 PCIe x8 Slot with x4 signal • 1 PCIe x16 Slot with x4 signal
M.2	<ul style="list-style-type: none"> • 1 M.2 Key B Socket (2280/3042/3052, PCIe/USB 3, default/SATA) • 1 M.2 Key E Socket (2230, PCIe/USB)
Graphics	
Graphics Processor	Intel® UHD Graphics 770/730 driven by Intel® X ^e Architecture
Interface	Up to 7 independent displays : <ul style="list-style-type: none"> • 2 HDMI 2.1 : Up to 4096 x 2304 @60Hz • 1 DP : Up to 3840 x 2160 @60Hz • 4 DP : Up to 7680 x 4320 @60Hz (By requested MXM)
Storage	
SATA	2 SATA III (6Gbps) support S/W RAID 0, 1 with 2 Front-access 2.5" SSD/HDD Tray
M.2	<ul style="list-style-type: none"> • 1 M.2 Key M Socket (2280, PCIe x4) • 2 Front-access M.2 Key M SSD Tray
Audio	
Audio Codec	Realtek® ALC888S-VD, 7.1 Channel HD Audio
Audio Interface	1 Mic-in, 1 Line-out

Ethernet	
LAN 1	Intel® I226 2.5GigE LAN supports TSN
LAN 2	Intel® I226 2.5GigE LAN supports TSN
Power	
Input Voltage	DC 9V to 55V
Power Interface	3-pin Terminal Block : V+, V-, Frame Ground
Ignition Control	16-mode Software Ignition Control
Remote Switch	3-pin Terminal Block : On, Off, IGN
Out-of-Band Management	
MCU	Nuvoton NUC980
Interface	OOB LAN, 10/100Mb Ethernet LAN, RJ45 Connector
Remote Management	Support Remote Power ON/OFF, Reset and Power Cycling
Others	
TPM	Infineon SLB9670 supports TPM 2.0, SPI Interface
Watchdog Timer	Reset : 1 to 255 sec./min. per step
Smart Management	Wake on LAN, PXE supported
HW Monitor	Monitoring temperature, voltages. Auto throttling control when CPU overheats.
Mechanical	
Dimension (W x D x H)	280 mm x 130 mm x 215 mm (11.02" x 5.19" x 8.46")
Weight	6.2 kg (13.67 lb)
Mounting	<ul style="list-style-type: none"> • Wall mount by mounting bracket • VESA Mount (Optional) • DIN Rail Mount (Optional) • Rackmount (Optional)
Environment	
Operating Temperature	35W TDP CPU : -25°C to 55°C (-13°F to 131°F) with air flow 65W TDP CPU : -25°C to 45°C (-13°F to 113°F) with air flow
Storage Temperature	-40°C to 85°C (-40°F to 185°F)
Humidity	5% to 95% humidity, non-condensing
Relative Humidity	95% @55°C
Shock	<ul style="list-style-type: none"> • IEC 60068-2-27 • SSD : 50G @wallmount, Half-sine, 11ms • MIL-STD-810G method 514.6, Category 4 (with PCIe Card)
Vibration	<ul style="list-style-type: none"> • IEC 60068-2-64 • SSD : 5Grms, 5Hz to 500Hz, 3 Axis • MIL-STD-810G method 516.6, Procedure I (with PCIe Card)
EMC	CE, FCC, ICES, EN50155, EN50121-3-2

1.3.3 Specifications of EVS-3200

System	
Processor	<ul style="list-style-type: none"> • 24-core Intel® Core™ i9/i7/i5/i3 Processor (14th gen, Raptor Lake-S Refresh) • 24-core 13th Gen Intel® Core™ i9/i7/i5/i3 Processor (Raptor Lake-S) • 16-core 12th Gen Intel® Core™ i9/i7/i5/i3 Processor (Alder Lake-S)
Chipset	Intel® R680E
BIOS	AMI
SIO	IT8786E
Memory	2 DDR5 5600MHz SO-DIMM, up to 96GB (ECC/Non-ECC)
OS	Windows 11, Windows 10, Linux
I/O Interface	
Serial	2 COM RS-232/422/485 (ESD 8kV)
USB	<ul style="list-style-type: none"> • 4 USB 3.2 Gen 2 Type A • 1 USB 3.2 Gen 2x2, USB Type-C supports max 20Gbps data transfer (15W, 5V/3A)
Isolated DIO	32 Isolated DIO : 16 DI, 16 DO
LED	Power, HDD, OOB
SIM Card	1 External SIM Card Socket for 5G/4G/LTE/GPRS/UMTS wireless network
Expansion	
PCIe	2 PCIe Slot : <ul style="list-style-type: none"> • 1 PCIe x8 Slot with x4 signal • 1 PCIe x16 Slot with x8 signal
M.2	<ul style="list-style-type: none"> • 1 M.2 Key B Socket (2280/3042/3052, PCIe/USB 3, default/SATA) • 1 M.2 Key E Socket (2230, PCIe/USB)
Graphics	
Graphics Processor	Intel® UHD Graphics 770/730 driven by Intel® X ^e Architecture
Interface	Up to 7 independent displays : <ul style="list-style-type: none"> • 2 HDMI 2.1 : Up to 4096 x 2304 @60Hz • 1 DP : Up to 3840 x 2160 @60Hz • 4 DP : Up to 7680 x 4320 @60Hz (By requested MXM)
Storage	
SATA	2 SATA III (6Gbps) support S/W RAID 0, 1 with 2 Front-access 2.5" SSD/HDD Tray
M.2	1 M.2 Key M Socket (2280, PCIe x4)
Audio	
Audio Codec	Realtek® ALC888S-VD, 7.1 Channel HD Audio
Audio Interface	1 Mic-in, 1 Line-out

Ethernet	
LAN 1	Intel® I226 2.5GigE LAN supports TSN
LAN 2	Intel® I226 2.5GigE LAN supports TSN
Power	
Input Voltage	DC 9V to 55V
Power Interface	3-pin Terminal Block : V+, V-, Frame Ground
Ignition Control	16-mode Software Ignition Control
Remote Switch	3-pin Terminal Block : On, Off, IGN
Out-of-Band Management	
MCU	Nuvoton NUC980
Interface	OOB LAN, 10/100Mb Ethernet LAN, RJ45 Connector
Remote Management	Support Remote Power ON/OFF, Reset and Power Cycling
Others	
TPM	Infineon SLB9670 supports TPM 2.0, SPI Interface
Watchdog Timer	Reset : 1 to 255 sec./min. per step
Smart Management	Wake on LAN, PXE supported
HW Monitor	Monitoring temperature, voltages. Auto throttling control when CPU overheats.
Mechanical	
Dimension (W x D x H)	280 mm x 114 mm x 215 mm (11.02" x 4.49" x 8.46")
Weight	5.6 kg (12.35 lb)
Mounting	<ul style="list-style-type: none"> • Wall mount by mounting bracket • VESA Mount (Optional) • DIN Rail Mount (Optional) • Rackmount (Optional)
Environment	
Operating Temperature	35W TDP CPU : -25°C to 55°C (-13°F to 131°F) with air flow 65W TDP CPU : -25°C to 45°C (-13°F to 113°F) with air flow
Storage Temperature	-40°C to 85°C (-40°F to 185°F)
Humidity	5% to 95% humidity, non-condensing
Relative Humidity	95% @55°C
Shock	<ul style="list-style-type: none"> • IEC 60068-2-27 • SSD : 50G @wallmount, Half-sine, 11ms • MIL-STD-810G method 514.6, Category 4 (with PCIe Card)
Vibration	<ul style="list-style-type: none"> • IEC 60068-2-64 • SSD : 5Grms, 5Hz to 500Hz, 3 Axis • MIL-STD-810G method 516.6, Procedure I (with PCIe Card)
EMC	CE, FCC, ICES, EN50155, EN50121-3-2

1.3.4 Specifications of EVS-3100

System	
Processor	<ul style="list-style-type: none"> • 24-core Intel® Core™ i9/i7/i5/i3 Processor (14th gen, Raptor Lake-S Refresh) • 24-core 13th Gen Intel® Core™ i9/i7/i5/i3 Processor (Raptor Lake-S) • 16-core 12th Gen Intel® Core™ i9/i7/i5/i3 Processor (Alder Lake-S)
Chipset	Intel® R680E
BIOS	AMI
SIO	IT8786E
Memory	2 DDR5 5600MHz SO-DIMM, up to 96GB (ECC/Non-ECC)
OS	Windows 11, Windows 10, Linux
I/O Interface	
Serial	2 COM RS-232/422/485 (ESD 8kV)
USB	<ul style="list-style-type: none"> • 4 USB 3.2 Gen 2 Type A • 1 USB 3.2 Gen 2x2, USB Type-C supports max 20Gbps data transfer (15W, 5V/3A)
Isolated DIO	32 Isolated DIO : 16 DI, 16 DO
LED	Power, HDD, OOB
SIM Card	1 External SIM Card Socket for 5G/4G/LTE/GPRS/UMTS wireless network
Expansion	
PCIe	1 PCIe x16 Slot with x8 signal
M.2	<ul style="list-style-type: none"> • 1 M.2 Key B Socket (2280/3042/3052, PCIe/USB 3, default/SATA) • 1 M.2 Key E Socket (2230, PCIe/USB)
Graphics	
Graphics Processor	Intel® UHD Graphics 770/730 driven by Intel® X ^e Architecture
Interface	Up to 7 independent displays : <ul style="list-style-type: none"> • 2 HDMI 2.1 : Up to 4096 x 2304 @60Hz • 1 DP : Up to 3840 x 2160 @60Hz • 4 DP : Up to 7680 x 4320 @60Hz (By requested MXM)
Storage	
SATA	2 SATA III (6Gbps) support S/W RAID 0, 1 with 2 Front-access 2.5" SSD/HDD Tray
M.2	1 M.2 Key M Socket (2280, PCIe x4)
Audio	
Audio Codec	Realtek® ALC888S-VD, 7.1 Channel HD Audio
Audio Interface	1 Mic-in, 1 Line-out
Ethernet	
LAN 1	Intel® I226 2.5GigE LAN supports TSN
LAN 2	Intel® I226 2.5GigE LAN supports TSN

Power	
Input Voltage	DC 9V to 55V
Power Interface	3-pin Terminal Block : V+, V-, Frame Ground
Ignition Control	16-mode Software Ignition Control
Remote Switch	3-pin Terminal Block : On, Off, IGN
Out-of-Band Management	
MCU	Nuvoton NUC980
Interface	OOB LAN, 10/100Mb Ethernet LAN, RJ45 Connector
Remote Management	Support Remote Power ON/OFF, Reset and Power Cycling
Others	
TPM	Infineon SLB9670 supports TPM 2.0, SPI Interface
Watchdog Timer	Reset : 1 to 255 sec./min. per step
Smart Management	Wake on LAN, PXE supported
HW Monitor	Monitoring temperature, voltages. Auto throttling control when CPU overheats.
Mechanical	
Dimension (W x D x H)	280 mm x 90 mm x 215 mm (11.02" x 3.54" x 8.46")
Weight	5.0 kg (11.02 lb)
Mounting	<ul style="list-style-type: none"> • Wall mount by mounting bracket • VESA Mount (Optional) • DIN Rail Mount (Optional) • Rackmount (Optional)
Environment	
Operating Temperature	35W TDP CPU : -25°C to 55°C (-13°F to 131°F) with air flow 65W TDP CPU : -25°C to 45°C (-13°F to 113°F) with air flow
Storage Temperature	-40°C to 85°C (-40°F to 185°F)
Humidity	5% to 95% humidity, non-condensing
Relative Humidity	95% @55°C
Shock	<ul style="list-style-type: none"> • IEC 60068-2-27 • SSD : 50G @wallmount, Half-sine, 11ms • MIL-STD-810G method 514.6, Category 4 (with PCIe Card)
Vibration	<ul style="list-style-type: none"> • IEC 60068-2-64 • SSD : 5Gms, 5Hz to 500Hz, 3 Axis • MIL-STD-810G method 516.6, Procedure I (with PCIe Card)
EMC	CE, FCC, ICES, EN50155, EN50121-3-2

1.3.5 Specifications of EVS-3400F

System	
Processor	<ul style="list-style-type: none"> • 24-core Intel® Core™ i9/i7/i5/i3 Processor (14th gen, Raptor Lake-S Refresh) • 24-core 13th Gen Intel® Core™ i9/i7/i5/i3 Processor (Raptor Lake-S) • 16-core 12th Gen Intel® Core™ i9/i7/i5/i3 Processor (Alder Lake-S)
Chipset	Intel® R680E
BIOS	AMI
SIO	IT8786E
Memory	2 DDR5 5600MHz SO-DIMM, up to 96GB (ECC/Non-ECC)
OS	Windows 11, Windows 10, Linux
I/O Interface	
Serial	2 COM RS-232/422/485 (ESD 8kV)
USB	<ul style="list-style-type: none"> • 4 USB 3.2 Gen 2 Type A • 1 USB 3.2 Gen 2x2, USB Type-C supports max 20Gbps data transfer (15W, 5V/3A)
Isolated DIO	32 Isolated DIO : 16 DI, 16 DO
LED	Power, HDD, OOB
SIM Card	1 External SIM Card Socket for 5G/4G/LTE/GPRS/UMTS wireless network
Expansion	
PCIe	4 PCIe Slot : <ul style="list-style-type: none"> • 1 PCIe x16 Slot with x8 signal • 1 PCIe x8 Slot with x4 signal • 1 PCIe x16 Slot with x4 signal • 1 PCIe x8 Slot with x4 signal
M.2	<ul style="list-style-type: none"> • 1 M.2 Key B Socket (2280/3042/3052, PCIe/USB 3, default/SATA) • 1 M.2 Key E Socket (2230, PCIe/USB)
Graphics	
Graphics Processor	Intel® UHD Graphics 770/730 driven by Intel® X ^e Architecture
Interface	Up to 7 independent displays : <ul style="list-style-type: none"> • 2 HDMI 2.1 : Up to 4096 x 2304 @60Hz • 1 DP : Up to 3840 x 2160 @60Hz • 4 DP : Up to 7680 x 4320 @60Hz (By requested MXM)
Storage	
SATA	2 SATA III (6Gbps) support S/W RAID 0, 1 with 2 Front-access 2.5" SSD/HDD Tray
M.2	<ul style="list-style-type: none"> • 1 M.2 Key M Socket (2280, PCIe x4) • 2 Front-access M.2 Key M SSD Tray
Audio	

Audio Codec	Realtek® ALC888S-VD, 7.1 Channel HD Audio
Audio Interface	1 Mic-in, 1 Line-out
Ethernet	
LAN 1	Intel® I226 2.5GigE LAN supports TSN
LAN 2	Intel® I226 2.5GigE LAN supports TSN
Power	
Input Voltage	DC 9V to 55V
Power Interface	3-pin Terminal Block : V+, V-, Frame Ground
Ignition Control	16-mode Software Ignition Control
Remote Switch	3-pin Terminal Block : On, Off, IGN
Out-of-Band Management	
MCU	Nuvoton NUC980
Interface	OOB LAN, 10/100Mb Ethernet LAN, RJ45 Connector
Remote Management	Support Remote Power ON/OFF, Reset and Power Cycling
Others	
TPM	Infineon SLB9670 supports TPM 2.0, SPI Interface
Watchdog Timer	Reset : 1 to 255 sec./min. per step
Smart Management	Wake on LAN, PXE supported
HW Monitor	Monitoring temperature, voltages. Auto throttling control when CPU overheats.
Mechanical	
Dimension (W x D x H)	280 mm x 159 mm x 215 mm (11.02" x 6.26" x 8.46")
Weight	6.9 kg (15.21 lb)
Mounting	<ul style="list-style-type: none"> • Wall mount by mounting bracket • VESA Mount (Optional) • DIN Rail Mount (Optional) • Rackmount (Optional)
Environment	
Operating Temperature	35W TDP CPU : -25°C to 55°C (-13°F to 131°F) with air flow 65W TDP CPU : -25°C to 45°C (-13°F to 113°F) with air flow
Storage Temperature	-40°C to 85°C (-40°F to 185°F)
Humidity	5% to 95% humidity, non-condensing
Relative Humidity	95% @55°C
Shock	<ul style="list-style-type: none"> • IEC 60068-2-27 • SSD : 50G @wallmount, Half-sine, 11ms • MIL-STD-810G method 514.6, Category 4 (with PCIe Card)
Vibration	<ul style="list-style-type: none"> • IEC 60068-2-64 • SSD : 5Grms, 5Hz to 500Hz, 3 Axis • MIL-STD-810G method 516.6, Procedure I (with PCIe Card)
EMC	CE, FCC, ICES, EN50155, EN50121-3-2

1.3.6 Specifications of EVS-3300F

System	
Processor	<ul style="list-style-type: none"> • 24-core Intel® Core™ i9/i7/i5/i3 Processor (14th gen, Raptor Lake-S Refresh) • 24-core 13th Gen Intel® Core™ i9/i7/i5/i3 Processor (Raptor Lake-S) • 16-core 12th Gen Intel® Core™ i9/i7/i5/i3 Processor (Alder Lake-S)
Chipset	Intel® R680E
BIOS	AMI
SIO	IT8786E
Memory	2 DDR5 5600MHz SO-DIMM, up to 96GB (ECC/Non-ECC)
OS	Windows 11, Windows 10, Linux
I/O Interface	
Serial	2 COM RS-232/422/485 (ESD 8kV)
USB	<ul style="list-style-type: none"> • 4 USB 3.2 Gen 2 Type A • 1 USB 3.2 Gen 2x2, USB Type-C supports max 20Gbps data transfer (15W, 5V/3A)
Isolated DIO	32 Isolated DIO : 16 DI, 16 DO
LED	Power, HDD, OOB
SIM Card	1 External SIM Card Socket for 5G/4G/LTE/GPRS/UMTS wireless network
Expansion	
PCIe	3 PCIe Slot : <ul style="list-style-type: none"> • 1 PCIe x16 Slot with x8 signal • 1 PCIe x8 Slot with x4 signal • 1 PCIe x16 Slot with x4 signal
M.2	<ul style="list-style-type: none"> • 1 M.2 Key B Socket (2280/3042/3052, PCIe/USB 3, default/SATA) • 1 M.2 Key E Socket (2230, PCIe/USB)
Graphics	
Graphics Processor	Intel® UHD Graphics 770/730 driven by Intel® X ^e Architecture
Interface	Up to 7 independent displays : <ul style="list-style-type: none"> • 2 HDMI 2.1 : Up to 4096 x 2304 @60Hz • 1 DP : Up to 3840 x 2160 @60Hz • 4 DP : Up to 7680 x 4320 @60Hz (By requested MXM)
Storage	
SATA	2 SATA III (6Gbps) support S/W RAID 0, 1 with 2 Front-access 2.5" SSD/HDD Tray
M.2	<ul style="list-style-type: none"> • 1 M.2 Key M Socket (2280, PCIe x4) • 2 Front-access M.2 Key M SSD Tray
Audio	

Audio Codec	Realtek® ALC888S-VD, 7.1 Channel HD Audio
Audio Interface	1 Mic-in, 1 Line-out
Ethernet	
LAN 1	Intel® I226 2.5GigE LAN supports TSN
LAN 2	Intel® I226 2.5GigE LAN supports TSN
Power	
Input Voltage	DC 9V to 55V
Power Interface	3-pin Terminal Block : V+, V-, Frame Ground
Ignition Control	16-mode Software Ignition Control
Remote Switch	3-pin Terminal Block : On, Off, IGN
Out-of-Band Management	
MCU	Nuvoton NUC980
Interface	OOB LAN, 10/100Mb Ethernet LAN, RJ45 Connector
Remote Management	Support Remote Power ON/OFF, Reset and Power Cycling
Others	
TPM	Infineon SLB9670 supports TPM 2.0, SPI Interface
Watchdog Timer	Reset : 1 to 255 sec./min. per step
Smart Management	Wake on LAN, PXE supported
HW Monitor	Monitoring temperature, voltages. Auto throttling control when CPU overheats.
Mechanical	
Dimension (W x D x H)	280 mm x 137 mm x 215 mm (11.02" x 5.39" x 8.46")
Weight	6.3 kg (13.89 lb)
Mounting	<ul style="list-style-type: none"> • Wall mount by mounting bracket • VESA Mount (Optional) • DIN Rail Mount (Optional) • Rackmount (Optional)
Environment	
Operating Temperature	35W TDP CPU : -25°C to 55°C (-13°F to 131°F) with air flow 65W TDP CPU : -25°C to 45°C (-13°F to 113°F) with air flow
Storage Temperature	-40°C to 85°C (-40°F to 185°F)
Humidity	5% to 95% humidity, non-condensing
Relative Humidity	95% @55°C
Shock	<ul style="list-style-type: none"> • IEC 60068-2-27 • SSD : 50G @wallmount, Half-sine, 11ms • MIL-STD-810G method 514.6, Category 4 (with PCIe Card)
Vibration	<ul style="list-style-type: none"> • IEC 60068-2-64 • SSD : 5Grms, 5Hz to 500Hz, 3 Axis • MIL-STD-810G method 516.6, Procedure I (with PCIe Card)
EMC	CE, FCC, ICES, EN50155, EN50121-3-2

1.3.7 Specifications of EVS-3200F

System	
Processor	<ul style="list-style-type: none"> • 24-core Intel® Core™ i9/i7/i5/i3 Processor (14th gen, Raptor Lake-S Refresh) • 24-core 13th Gen Intel® Core™ i9/i7/i5/i3 Processor (Raptor Lake-S) • 16-core 12th Gen Intel® Core™ i9/i7/i5/i3 Processor (Alder Lake-S)
Chipset	Intel® R680E
BIOS	AMI
SIO	IT8786E
Memory	2 DDR5 5600MHz SO-DIMM, up to 96GB (ECC/Non-ECC)
OS	Windows 11, Windows 10, Linux
I/O Interface	
Serial	2 COM RS-232/422/485 (ESD 8kV)
USB	<ul style="list-style-type: none"> • 4 USB 3.2 Gen 2 Type A • 1 USB 3.2 Gen 2x2, USB Type-C supports max 20Gbps data transfer (15W, 5V/3A)
Isolated DIO	32 Isolated DIO : 16 DI, 16 DO
LED	Power, HDD, OOB
SIM Card	1 External SIM Card Socket for 5G/4G/LTE/GPRS/UMTS wireless network
Expansion	
PCIe	2 PCIe Slot : <ul style="list-style-type: none"> • 1 PCIe x8 Slot with x4 signal • 1 PCIe x16 Slot with x8 signal
M.2	<ul style="list-style-type: none"> • 1 M.2 Key B Socket (2280/3042/3052, PCIe/USB 3, default/SATA) • 1 M.2 Key E Socket (2230, PCIe/USB)
Graphics	
Graphics Processor	Intel® UHD Graphics 770/730 driven by Intel® X ^e Architecture
Interface	Up to 7 independent displays : <ul style="list-style-type: none"> • 2 HDMI 2.1 : Up to 4096 x 2304 @60Hz • 1 DP : Up to 3840 x 2160 @60Hz • 4 DP : Up to 7680 x 4320 @60Hz (By requested MXM)
Storage	
SATA	2 SATA III (6Gbps) support S/W RAID 0, 1 with 2 Front-access 2.5" SSD/HDD Tray
M.2	1 M.2 Key M Socket (2280, PCIe x4)
Audio	
Audio Codec	Realtek® ALC888S-VD, 7.1 Channel HD Audio
Audio Interface	1 Mic-in, 1 Line-out

Ethernet	
LAN 1	Intel® I226 2.5GigE LAN supports TSN
LAN 2	Intel® I226 2.5GigE LAN supports TSN
Power	
Input Voltage	DC 9V to 55V
Power Interface	3-pin Terminal Block : V+, V-, Frame Ground
Ignition Control	16-mode Software Ignition Control
Remote Switch	3-pin Terminal Block : On, Off, IGN
Out-of-Band Management	
MCU	Nuvoton NUC980
Interface	OOB LAN, 10/100Mb Ethernet LAN, RJ45 Connector
Remote Management	Support Remote Power ON/OFF, Reset and Power Cycling
Others	
TPM	Infineon SLB9670 supports TPM 2.0, SPI Interface
Watchdog Timer	Reset : 1 to 255 sec./min. per step
Smart Management	Wake on LAN, PXE supported
HW Monitor	Monitoring temperature, voltages. Auto throttling control when CPU overheats.
Mechanical	
Dimension (W x D x H)	280 mm x 121 mm x 215 mm (11.02" x 4.76" x 8.46")
Weight	5.7 kg (12.57 lb)
Mounting	<ul style="list-style-type: none"> • Wall mount by mounting bracket • VESA Mount (Optional) • DIN Rail Mount (Optional) • Rackmount (Optional)
Environment	
Operating Temperature	35W TDP CPU : -25°C to 55°C (-13°F to 131°F) with air flow 65W TDP CPU : -25°C to 45°C (-13°F to 113°F) with air flow
Storage Temperature	-40°C to 85°C (-40°F to 185°F)
Humidity	5% to 95% humidity, non-condensing
Relative Humidity	95% @55°C
Shock	<ul style="list-style-type: none"> • IEC 60068-2-27 • SSD : 50G @wallmount, Half-sine, 11ms • MIL-STD-810G method 514.6, Category 4 (with PCIe Card)
Vibration	<ul style="list-style-type: none"> • IEC 60068-2-64 • SSD : 5Grms, 5Hz to 500Hz, 3 Axis • MIL-STD-810G method 516.6, Procedure I (with PCIe Card)
EMC	CE, FCC, ICES, EN50155, EN50121-3-2

1.3.8 Specifications of EVS-3100F

System	
Processor	<ul style="list-style-type: none"> • 24-core Intel® Core™ i9/i7/i5/i3 Processor (14th gen, Raptor Lake-S Refresh) • 24-core 13th Gen Intel® Core™ i9/i7/i5/i3 Processor (Raptor Lake-S) • 16-core 12th Gen Intel® Core™ i9/i7/i5/i3 Processor (Alder Lake-S)
Chipset	Intel® R680E
BIOS	AMI
SIO	IT8786E
Memory	2 DDR5 5600MHz SO-DIMM, up to 96GB (ECC/Non-ECC)
OS	Windows 11, Windows 10, Linux
I/O Interface	
Serial	2 COM RS-232/422/485 (ESD 8kV)
USB	<ul style="list-style-type: none"> • 4 USB 3.2 Gen 2 Type A • 1 USB 3.2 Gen 2x2, USB Type-C supports max 20Gbps data transfer (15W, 5V/3A)
Isolated DIO	32 Isolated DIO : 16 DI, 16 DO
LED	Power, HDD, OOB
SIM Card	1 External SIM Card Socket for 5G/4G/LTE/GPRS/UMTS wireless network
Expansion	
PCIe	1 PCIe x16 Slot with x8 signal
M.2	<ul style="list-style-type: none"> • 1 M.2 Key B Socket (2280/3042/3052, PCIe/USB 3, default/SATA) • 1 M.2 Key E Socket (2230, PCIe/USB)
Graphics	
Graphics Processor	Intel® UHD Graphics 770/730 driven by Intel® X ^e Architecture
Interface	Up to 7 independent displays : <ul style="list-style-type: none"> • 2 HDMI 2.1 : Up to 4096 x 2304 @60Hz • 1 DP : Up to 3840 x 2160 @60Hz • 4 DP : Up to 7680 x 4320 @60Hz (By requested MXM)
Storage	
SATA	2 SATA III (6Gbps) support S/W RAID 0, 1 with 2 Front-access 2.5" SSD/HDD Tray
M.2	1 M.2 Key M Socket (2280, PCIe x4)
Audio	
Audio Codec	Realtek® ALC888S-VD, 7.1 Channel HD Audio
Audio Interface	1 Mic-in, 1 Line-out
Ethernet	
LAN 1	Intel® I226 2.5GigE LAN supports TSN
LAN 2	Intel® I226 2.5GigE LAN supports TSN

Power	
Input Voltage	DC 9V to 55V
Power Interface	3-pin Terminal Block : V+, V-, Frame Ground
Ignition Control	16-mode Software Ignition Control
Remote Switch	3-pin Terminal Block : On, Off, IGN
Out-of-Band Management	
MCU	Nuvoton NUC980
Interface	OOB LAN, 10/100Mb Ethernet LAN, RJ45 Connector
Remote Management	Support Remote Power ON/OFF, Reset and Power Cycling
Others	
TPM	Infineon SLB9670 supports TPM 2.0, SPI Interface
Watchdog Timer	Reset : 1 to 255 sec./min. per step
Smart Management	Wake on LAN, PXE supported
HW Monitor	Monitoring temperature, voltages. Auto throttling control when CPU overheats.
Mechanical	
Dimension (W x D x H)	280 mm x 97 mm x 215 mm (11.02" x 3.82" x 8.46")
Weight	5.1 kg (11.24 lb)
Mounting	<ul style="list-style-type: none"> • Wall mount by mounting bracket • VESA Mount (Optional) • DIN Rail Mount (Optional) • Rackmount (Optional)
Environment	
Operating Temperature	35W TDP CPU : -25°C to 55°C (-13°F to 131°F) with air flow 65W TDP CPU : -25°C to 45°C (-13°F to 113°F) with air flow
Storage Temperature	-40°C to 85°C (-40°F to 185°F)
Humidity	5% to 95% humidity, non-condensing
Relative Humidity	95% @55°C
Shock	<ul style="list-style-type: none"> • IEC 60068-2-27 • SSD : 50G @wallmount, Half-sine, 11ms • MIL-STD-810G method 514.6, Category 4 (with PCIe Card)
Vibration	<ul style="list-style-type: none"> • IEC 60068-2-64 • SSD : 5Gms, 5Hz to 500Hz, 3 Axis • MIL-STD-810G method 516.6, Procedure I (with PCIe Card)
EMC	CE, FCC, ICES, EN50155, EN50121-3-2

1.4 Supported CPU List

Series	CPU	Cores	GHz	TDP (W)	CPU	Cores	GHz	TDP (W)
Intel® Core™	i9-14900	24	5.8	65	i9-14900T	24	5.5	35
	i7-14700	20	5.4		i7-14700T	20	5.2	
	i5-14500	14	5		i5-14500T	14	4.8	
	i3-14100	4	4.7		i3-14100T	4	4.4	
	i9-13900E	24	5.2		i9-13900TE	24	5	
	i7-13700E	16	5.1		i7-13700TE	16	4.8	
	i5-13500E	14	4.6		i5-13500TE	14	4.5	
	i3-13100E	4	4.4		i3-13100TE	4	4.1	
	i9-12900E	16	5		i9-12900TE	16	4.8	
	i7-12700E	12	4.8		i7-12700TE	12	4.7	
	i5-12500E	6	4.5		i5-12500TE	6	4.3	
	i3-12100E	4	4.2		i3-12100TE	4	4	

1.5 Mechanical Dimension

1.5.1 Dimensions of EVS-3400

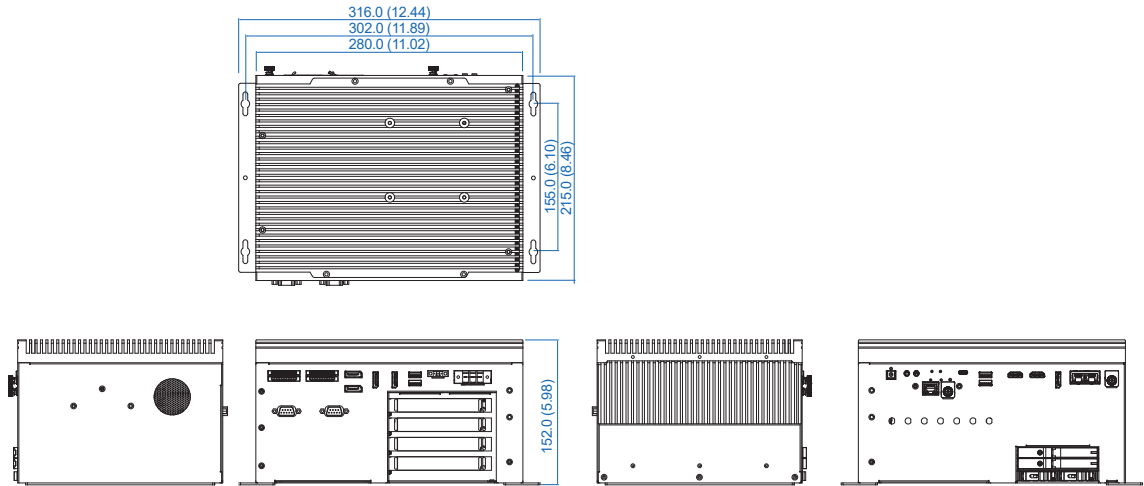

Unit: mm (inch)

1.5.2 Dimensions of EVS-3300

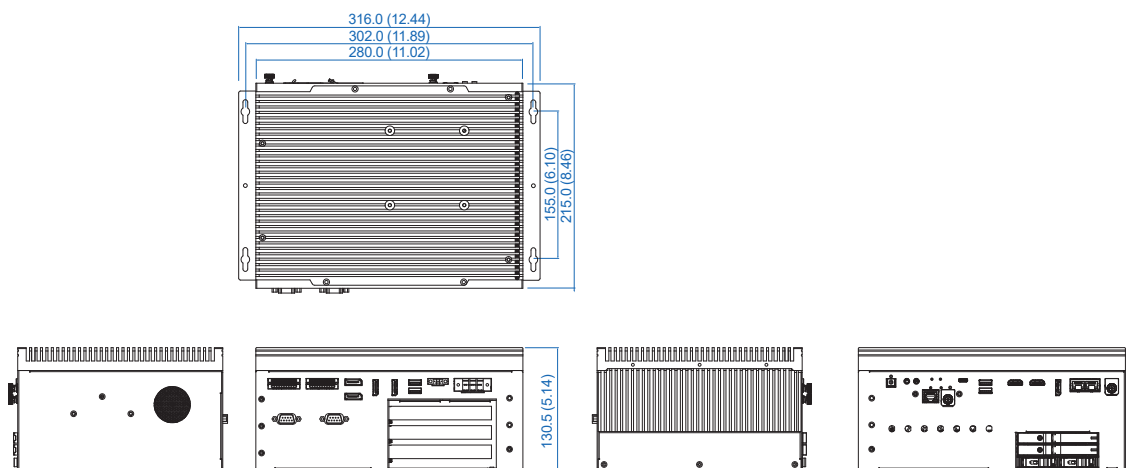

Unit: mm (inch)

1.5.3 Dimensions of EVS-3200

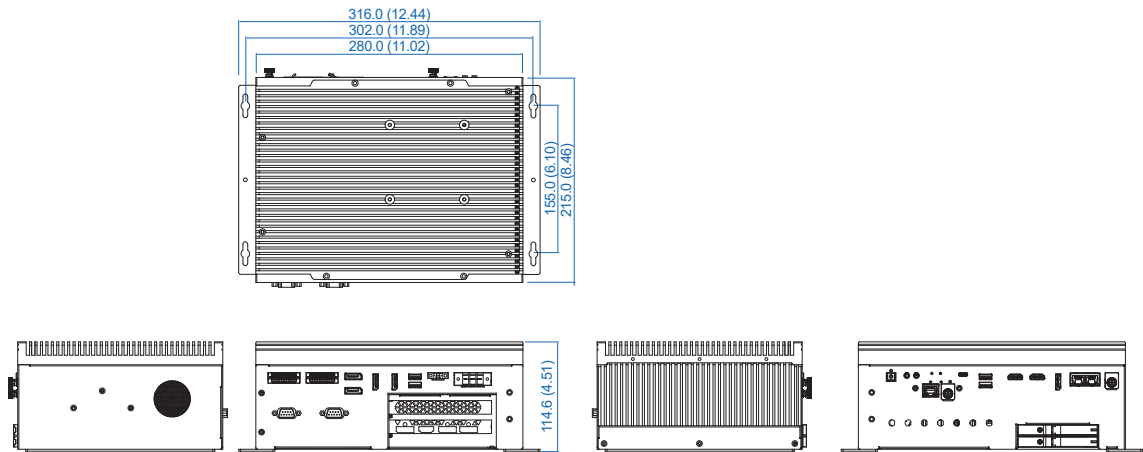

Unit: mm (inch)

1.5.4 Dimensions of EVS-3100

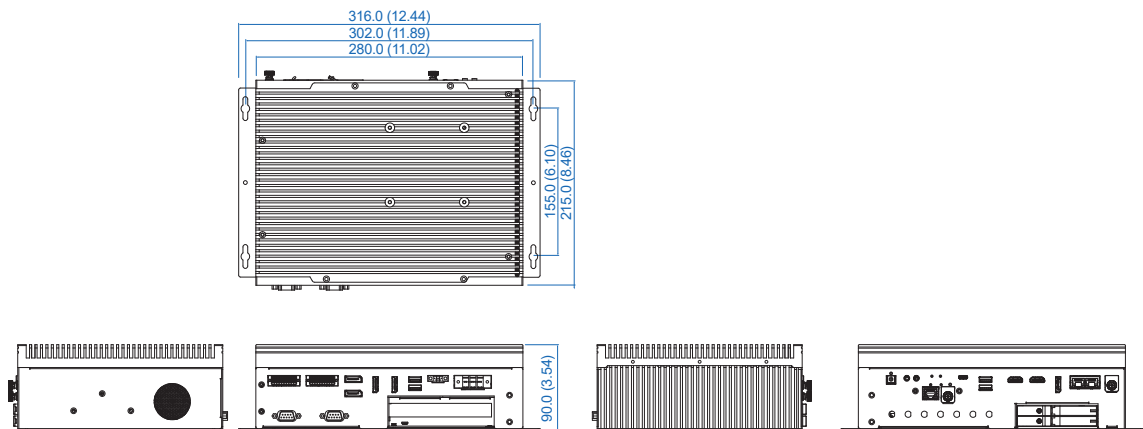

Unit: mm (inch)

1.5.5 Dimensions of EVS-3400F

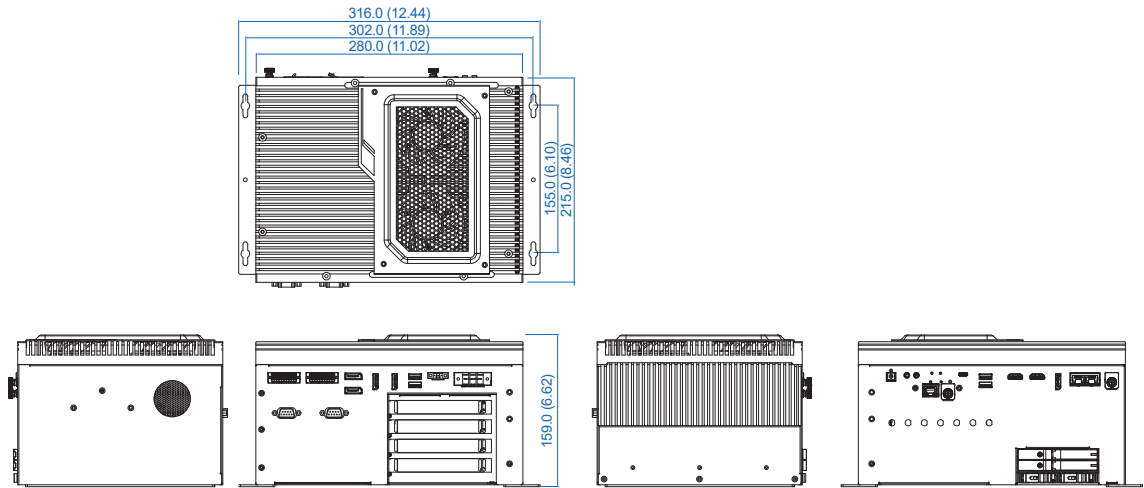

Unit: mm (inch)

1.5.6 Dimensions of EVS-3300F

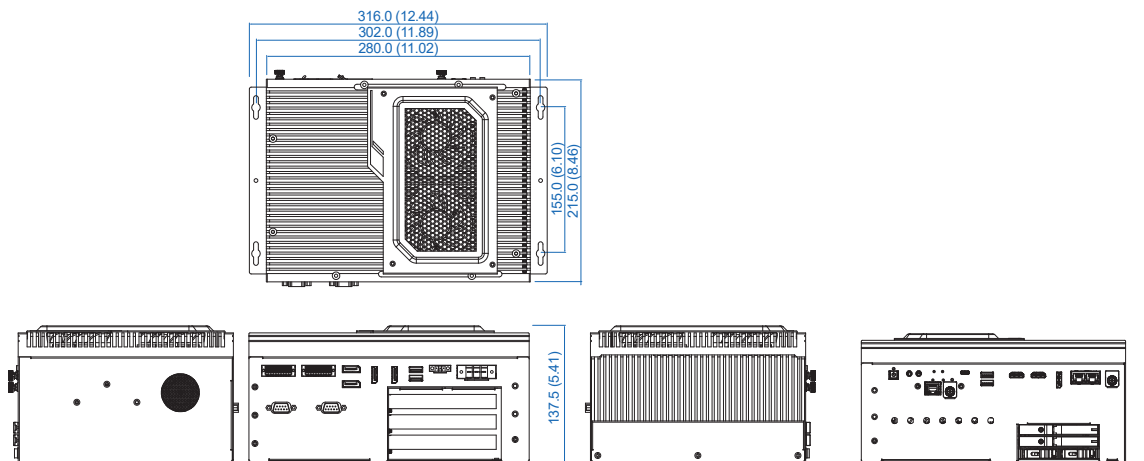

Unit: mm (inch)

1.5.7 Dimensions of EVS-3200F

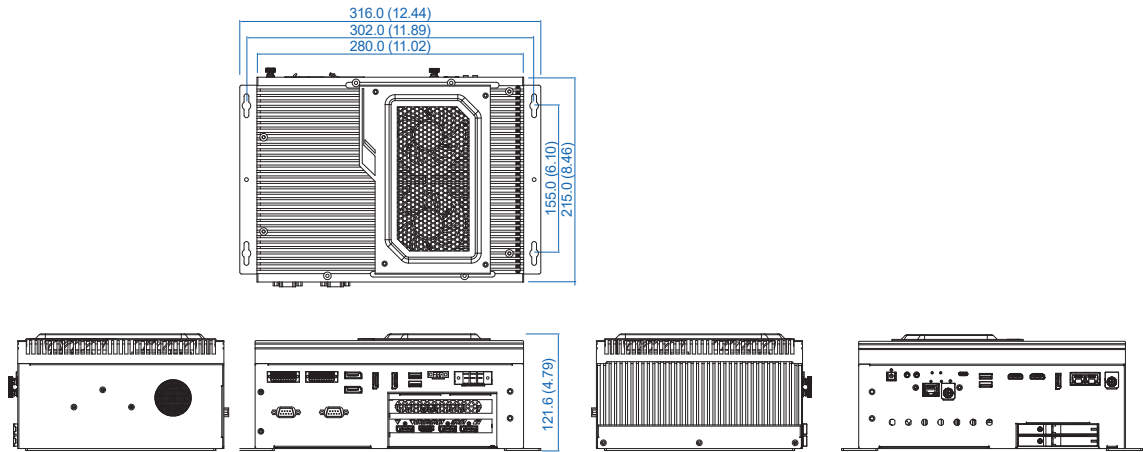

Unit: mm (inch)

1.5.8 Dimensions of EVS-3100F

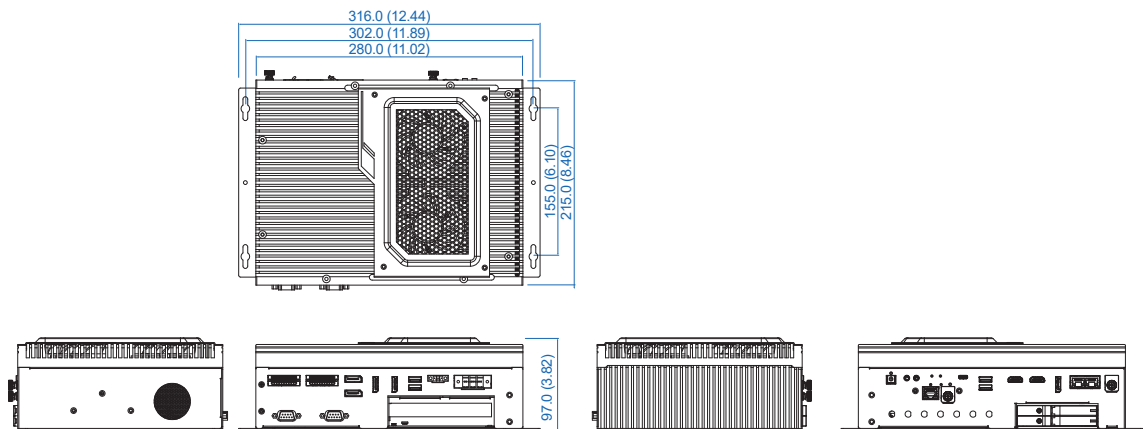

Unit: mm (inch)

2

GETTING TO KNOW YOUR EVS-3000

2.1 Packing List of EVS-3000/3000F

2.1.1 Packing List of EVS-3100(F)/3200(F)

Item	Description	Qty
1	EVS-3000 Expandable Fanless Embedded System (According to the configuration of you order, the EVS-3000 series may contain SSD/HDD and DDR5 SO-DIMM. Please verify these items if necessary.)	1
2	EVS-3000 series accessory box, which contains list below	1

Item	Description	Outlook	Usage	P/N	Qty
1	Terminal block 3-pin (7.62mm)		DC-IN	51-2611R03-S1N	1
2	Terminal block 20-pin (2.54mm)		Isolated DIO	51-2112R20-S1D	2
3	Terminal block 3-pin (3.5mm)		Remote SW/IGN	51-2211R03-S1A	1
4	GPU power cable		Graphic card	61-1400006-0G5	1
5	SSD Tray Key		SSD Tray	NA	2
6	Wall-mounting bracket		Mount	62-03P1711-01A	2
7	PHILLPIS I-M3x6L		Fasten Wall mount	53-M004950-310	6
9	Thermal grease		CPU	53-4000342-203	1
9	P-M3*6L		Fasten M.2	53-2426206-80B	4
10	Foot pad.		Foot pad.	53-4000042-303	4
11	M.2 TRAY		M.2-B.KEY	62-03P0997-30A	1

2.1.2 Packing List of EVS-3300(F)/3400(F)

Item	Description	Qty
1	EVS-3000 Expandable Fanless Embedded System (According to the configuration of you order, the EVS-3000 series may contain SSD/HDD and DDR5 SO-DIMM. Please verify these items if necessary.)	1
2	EVS-3000 series accessory box, which contains list below	1

Item	Description	Outlook	Usage	P/N	Qty
1	Terminal block 3-pin (7.62mm)		DC-IN	51-2611R03-S1N	1
2	Terminal block 20-pin (2.54mm)		Isolated DIO	51-2112R20-S1D	2
3	Terminal block 3-pin (3.5mm)		Remote SW/IGN	51-2211R03-S1A	1
4	GPU power cable		Graphic card	61-1400006-0G5	1
5	SSD Tray Key		SSD Tray	NA	2
6	M.2 Tray		M.2 Tray	NA	2
7	Wall-mounting bracket		Mount	62-03P1711-01A	2
9	PHILLPIS I-M3x6L		Fasten Wall mount	53-M004950-310	6
9	Thermal grease		CPU	53-4000342-203	1
10	P-M3*6L		Fasten M.2	53-2426206-80B	4
11	Foot pad.		Foot pad.	53-4000042-303	4
12	M.2 TRAY		M.2-B.KEY	62-03P0997-30A	1

2.2 Front Panel I/O & Functions

In Vecow EVS-3000 series family, all I/O connectors are located on front panel and rear panel. Most of the general connections to computer device, such as USB3.2, LAN, Audio, Display, HDMI, TypeC and any additional storage, are placed on the front panel.

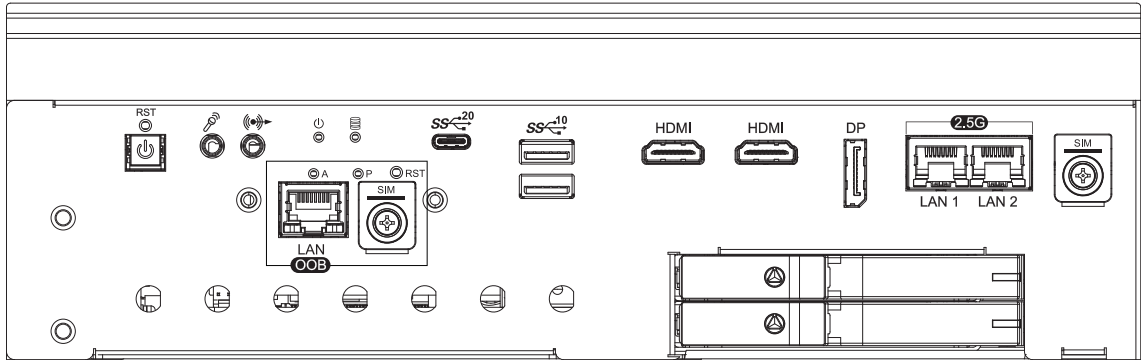

2.2.1 Power Button and Power LED

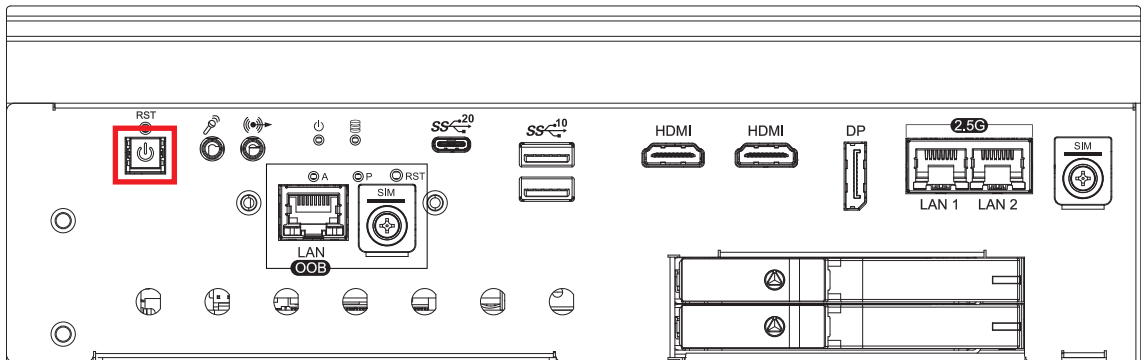

The Power Button is a non-latched switch with dual color LED indication. It indicates power status: S0, S3 and S5. More detail LED indications are listed as follows:

LED Color	Power Status	System Status
Solid Blue	S0	System working
Solid Orange	S3, S5	Suspend to RAM, System off with standby power

To power on the system, press the power button and then the blue LED is lightened. To power off the system, you can either command shutdown by OS operation, or just simply press the power button.

If system error, you can just press the power button for 4 seconds to shut down the machine directly. Please do note that a 4-second interval between each 2 power-on/ power-off operation is necessary in normal working status. (For example, once turning off the system, you have to wait for 4 seconds to initiate another power-on operation.)

2.2.2 Reset Tact Switch

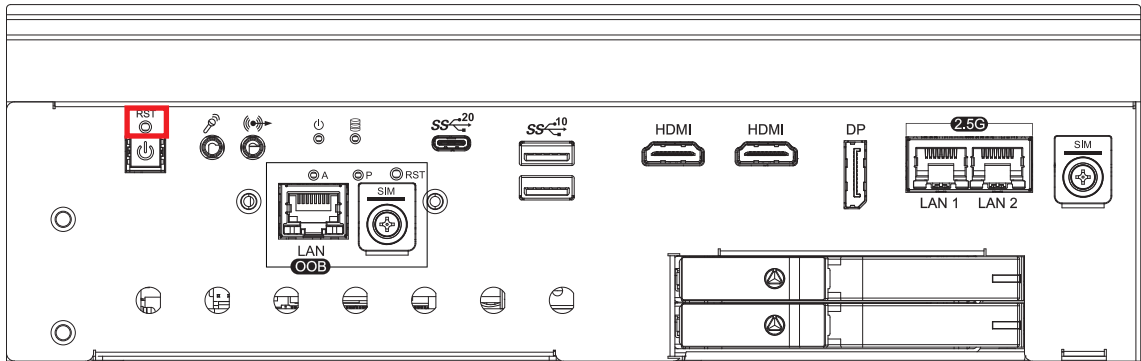

It is a hardware reset switch. Use this switch to reset the system without power off the system. Press the Reset Switch for a few seconds, and then reset will be enabled.

2.2.3 SIM SLOT

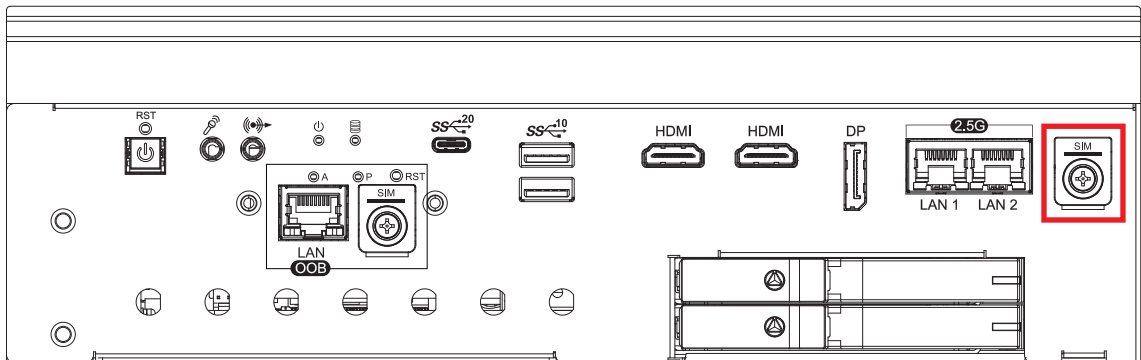

SIM mapping table as below table :

SIM Slot	Source Connector
SIM	M2B_CN1

Note :

The Nano SIM card sockets do not support hot-plug. Please make sure to unplug the system power before inserting the Nano SIM card(s).

2.2.4 PWR & HDD LED Indicator

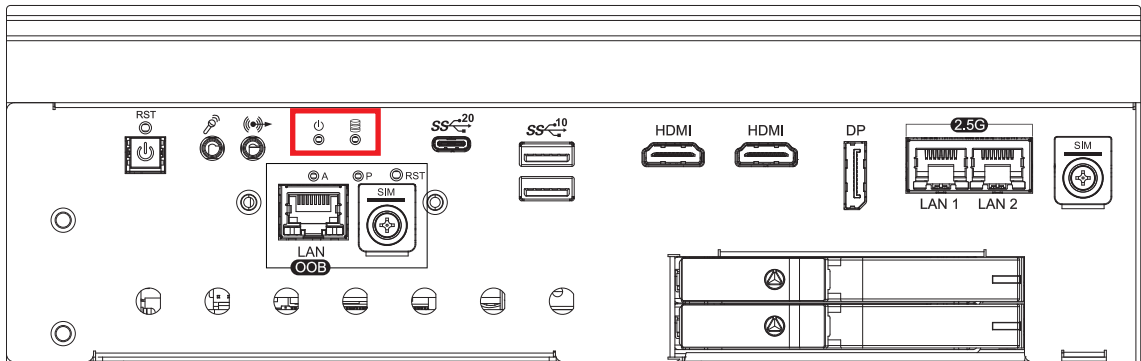

HDD LED/ Yellow : A hard disk/M.2 M key/SLIMSAS SSD LED. If the LED is on, it indicates that EVS-3000 series storage is functional. If it is off, it indicates that the system's storage is not functional. If it is flashing, it indicates data access activities.

Power LED/ Green : If the LED is solid green, it indicates that the system is powered on.

LED Color	Indication	System Status
Yellow	HDD	<ul style="list-style-type: none"> On/Off : Storage status, function or not Twinkling : Data transferring
Green	Power	System power status (on/off)

2.2.5 HDMI Connector

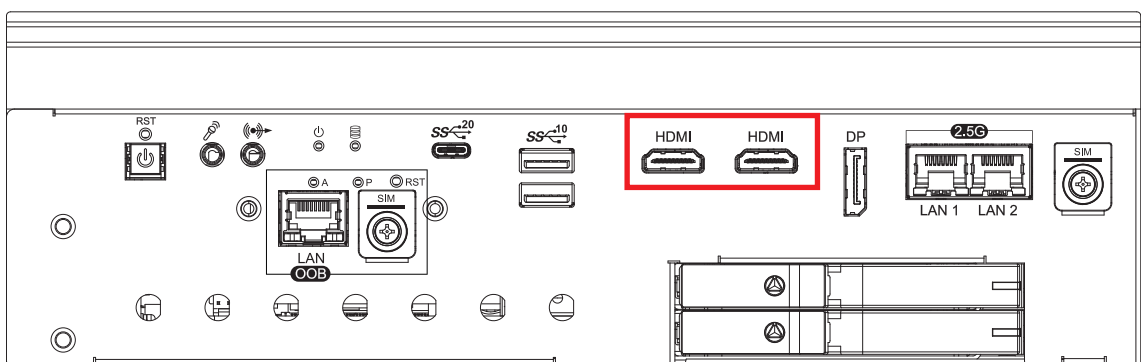

Onboard HDMI Port supports DDC channel mode. The connection supports up to 4096 x 2304 resolution at 60Hz.

2.2.6 USB Type-C

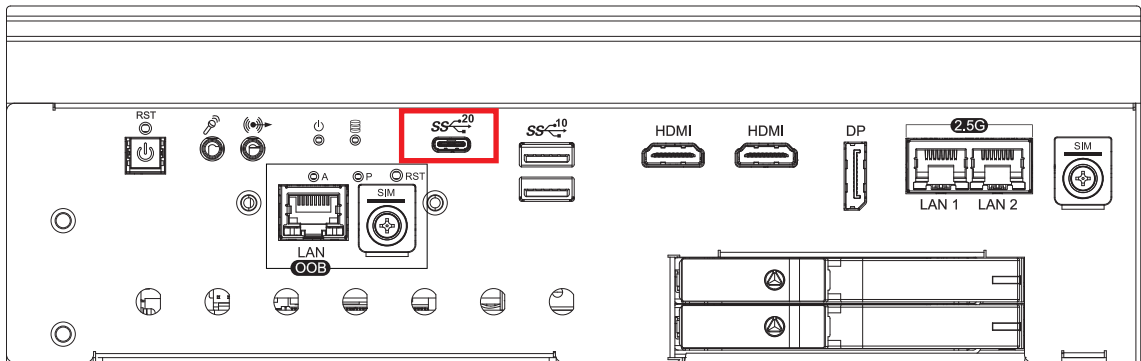

USB Type-C connector support up to 20GB per second data rate in the front side of EVS-3000 series.

2.2.7 DisplayPort

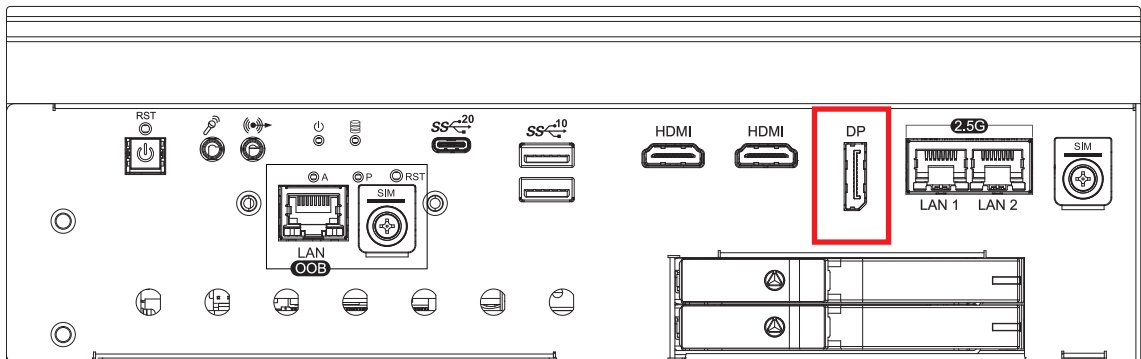

Onboard Display Port supports auxiliary channel dual mode, and the connection supports up to 3840 x 2160 resolution at 60 Hz.

Multi-Stream Transport Display Resolutions Table :

Multi-Stream Transport Display	Max. Resolution
Two panel Displays concurrently	3840 x 2160 @60Hz

2.2.8 USB 3.2 Gen2

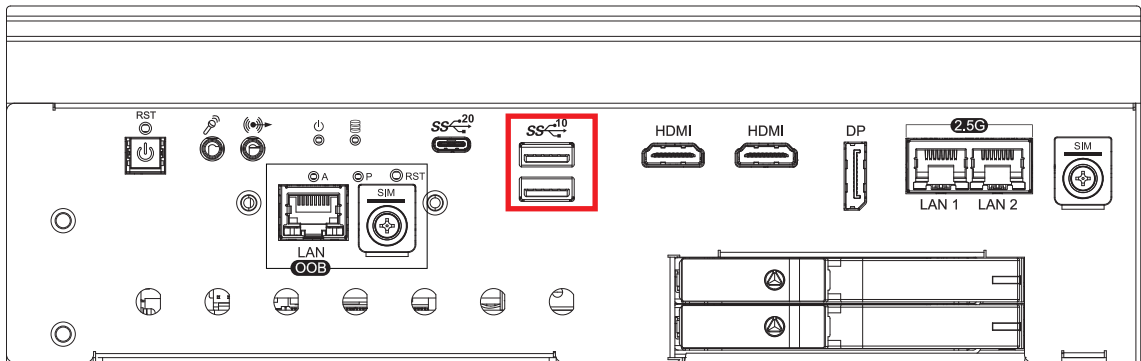

There are 2 USB 3.2 Gen2 Type A connections available supporting up to 10GB per second data rate in the front side of EVS-3000 series . It also compliant with the requirements of Super Speed (SS), high speed (HS), full speed (FS) and low speed (LS).

2.2.9 Ethernet Port

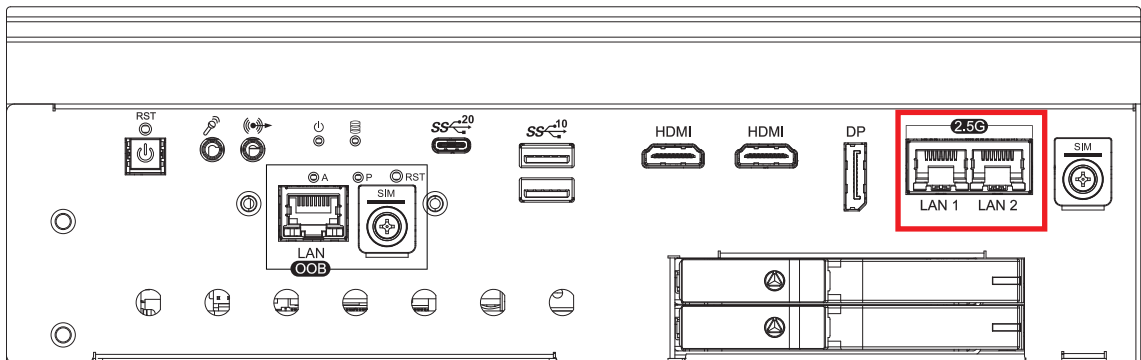

There are two 8-pin RJ-45 jacks supporting 10/100/1000/2500 Mbps Ethernet connections in the Rear side. LAN is powered by Intel i226-IT Ethernet engine. When both of LANs work in normal status, iAMT function is enabled. Using suitable RJ-45 cable, you can connect the system to a computer, or to any other devices with Ethernet connection, for example, a hub or a switch. Moreover, both of LANs support Wake on LAN and Pre-boot functions.

LAN Chip	Function	Connetor
Intel I226	RJ45(10/100/1000/2500Mbps)	LAN1
Intel I226	RJ45(10/100/1000/2500Mbps)	LAN2

Using suitable RJ-45 cable, you can connect the EVS-3000 series system to a computer or to any other devices with Ethernet connection, for example, a hub or a switch. Moreover, both LAN 1 and LAN 2 support “Wake” on LAN functions. The pinouts of LAN 1 and LAN 2 are listed in the following chart:

Pin No.	10/ 100 Mbps	1000 Mbps	2500 Mbps
1	E_TX+	MDI0_P	MDI0_P
2	E_TX-	MDI0_N	MDI0_N
3	E_RX+	MDI1_P	MDI1_P
4	----	MDI2_P	MDI2_P
5	----	MDI2_N	MDI2_N
6	E_RX-	MDI1_N	MDI1_N
7	----	MDI3_P	MDI3_P
8	----	MDI3_N	MDI3_N

Each LAN port is supported by standard RJ-45 connector with LED indicators to present Active/Link/Speed status of the connection.

The LED indicator on the right bottom corner lightens in solid Yellow when the cable is properly connected to a 1000 Mbps Ethernet network; The LED indicator on the right bottom corner lightens in solid Green when the cable is properly connected to a 2500Mbps Ethernet network; The left LED will keep twinkling/off when Ethernet data packets are being transmitted/received.

LED Location	LED Color	10Mbps	100Mbps	1000Mbps	2500Mbps
Right	Green/ Yellow	Off	Off	Solid Yellow	Solid Green
Left	Green	Twinkling Green	Twinkling Green	Twinkling Green	Twinkling Green

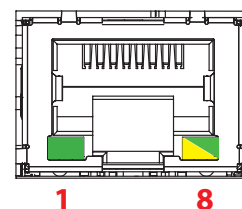

2.2.10 Audio Jack

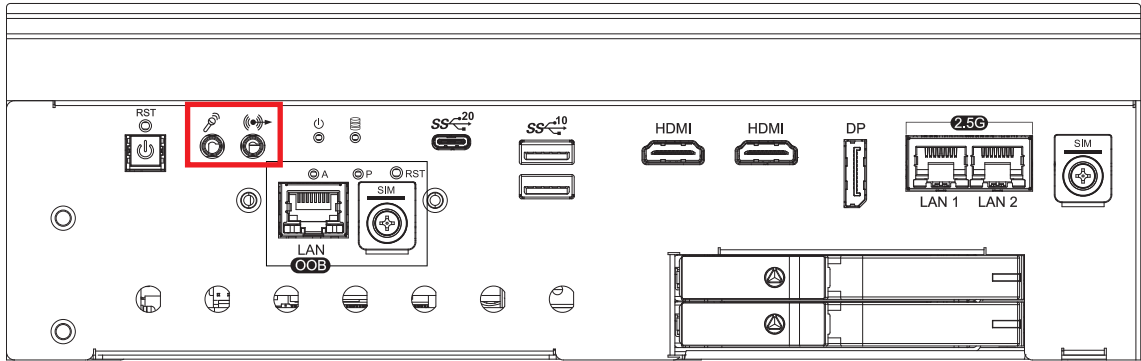

There are 2 audio connectors, Mic-in and Line-out, in the Front side of EVS-3000 series. Onboard Realtek ALC888 audio codec supports 7.1 channel HD audio and fully complies with Intel® High Definition Audio (Azalia) specifications.

To utilize the audio function in Windows platform, you need to install corresponding drivers for Realtek ALC888 codec

2.2.11 OOB Connector : Remote control ON/OFF/Reset.

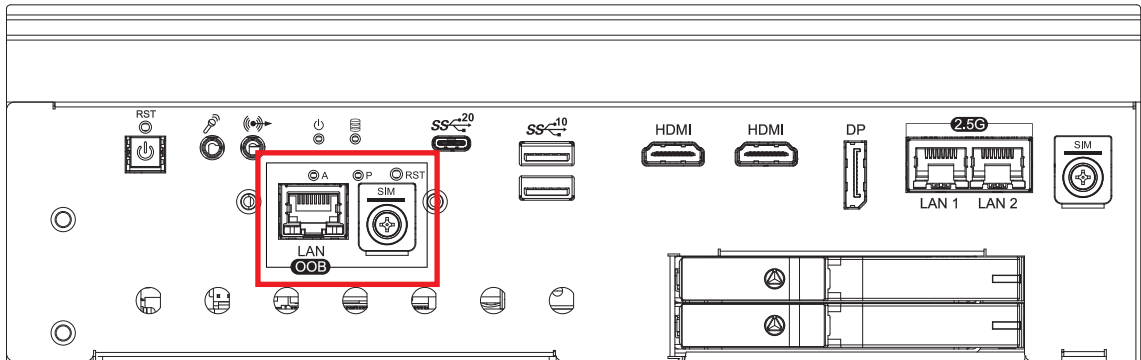

The LED indicator can instantly judge the power status(P) of OOB Enabler and the connection status(A) of OOB Enabler and Allxon Portal.

If both LEDs are on, it means OOB Enabler is running and the connection to Allxon Cloud is stable. The OOB network port is used for OOB out-of-band control.

The SIM card holder is used for OOB 4G network cards. This function is optional. For detailed instructions, please refer to the OOB chapter.

2.2.12 SSD/HDD Tray

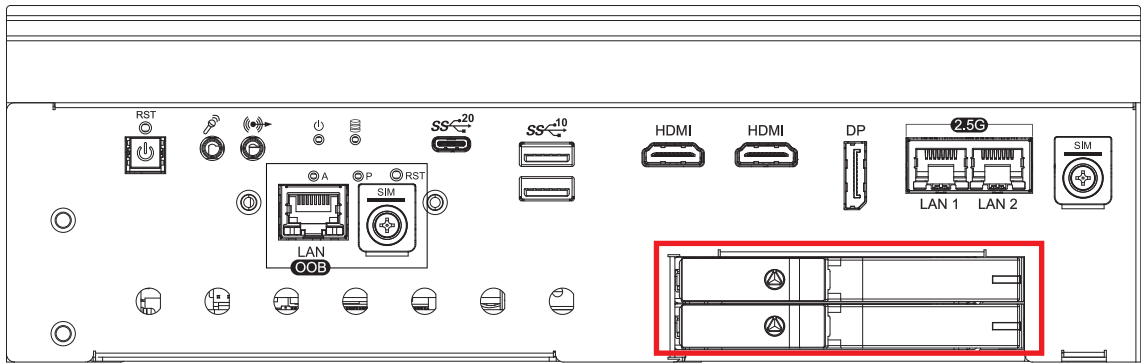

There are two front-access 2.5" SSD/HDD trays on the front side of EVS-3000 series. Press the trigger to open the SSD/HDD tray which has up to 8TB available

2.3 Rear Panel I/O & Functions

2.3.1 Power Terminal Block

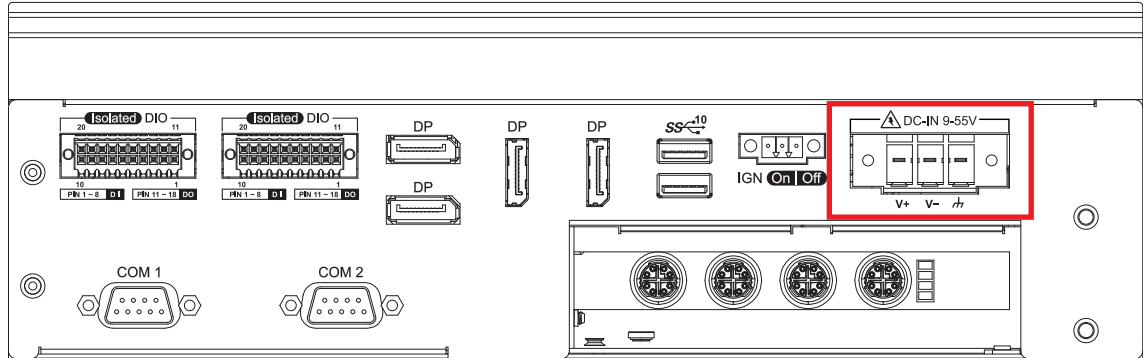

This system supports 9V to 55V DC power input by terminal block in the rear side. And the pin define is as below table.

Pin No.	Definition
1	V+
2	V-
3	Chassis Ground

2.3.2 Remote Power On/Off Switch & Ignition

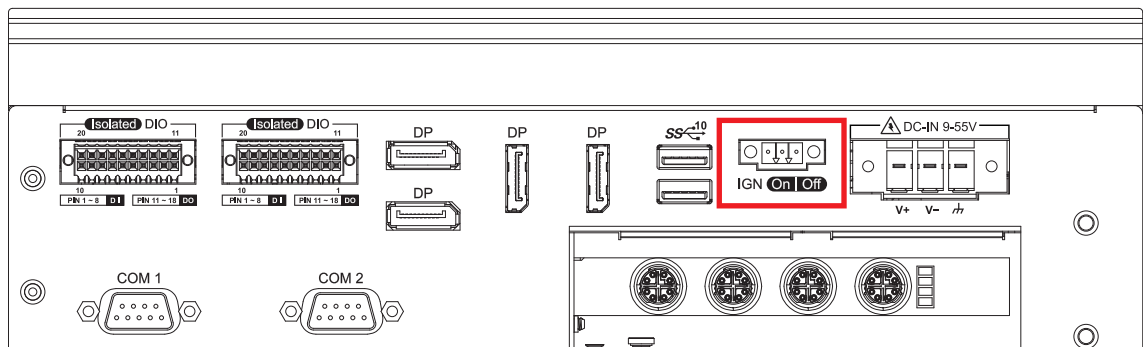

It is a 2-pin power-on or power-off switch through Phoenix Contact terminal block. You could turn on or off the system power by using this contact. This terminal block supports dual function of soft power-on/ power-off (instant off or delay 4 second), and suspend mode.

Pin No.	Definition
1	Ignition
2	SW+
3	SW-

2.3.3 COM Ports

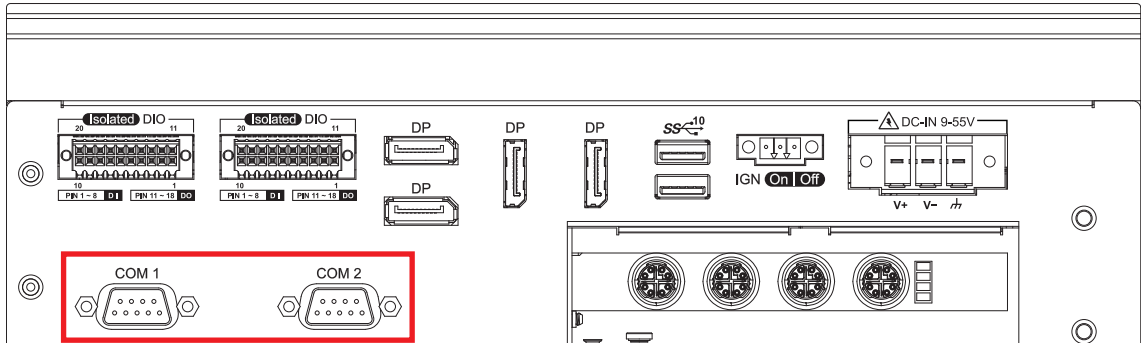

Serial port can be configured for RS-232, RS-422, or RS-485 with auto flow control communication. The default definition is RS-232, but if you want to change to RS-422 or RS-485, you can find the settings in BIOS.

BIOS Setting	Function
COM 1	RS-232
COM 2	RS-422(5-wire)
COM 3	RS-485
COM 4	RS-485 w/z auto-flow control

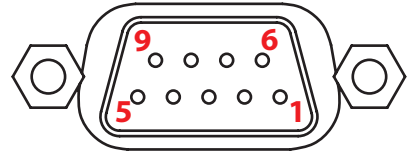

The pin assignments are listed in the table as follows :

Serial Port	Pin No.	RS-232	RS-422 (5-wire)	RS-485 (3-wire)
1 to 2	1	DCD	TXD-	DATA-
	2	RXD	TXD+	DATA+
	3	TXD	RXD+	-----
	4	DTR	RXD-	-----
	5	GND	GND	GND
	6	DSR	-----	-----
	7	RTS	-----	-----
	8	CTS	-----	-----
	9	RI	-----	-----

2.3.4 Rear USB 3.2 Gen2

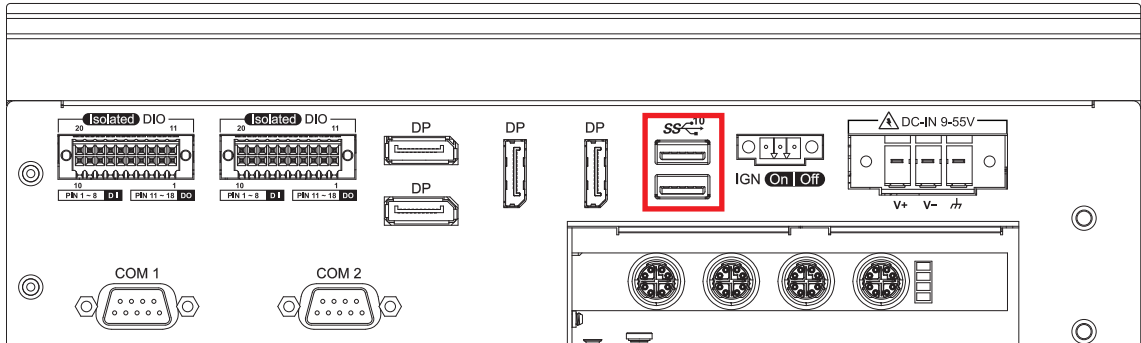

There are 2 USB 3.2 Gen2 Type A connections available supporting up to 10GB per second data rate in the front side of EVS-3000 series . It also compliant with the requirements of Super Speed (SS), high speed (HS), full speed (FS) and low speed (LS).

2.3.5 Display Port(4 from MXM)

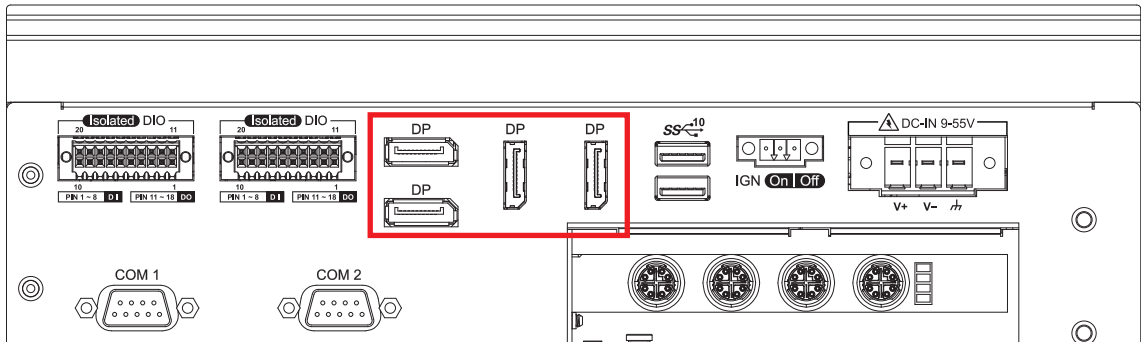

There are four Display Port Supports max resolution up to 7680x4320@60Hz (By requested MXM)

2.3.6 Isolated DIO

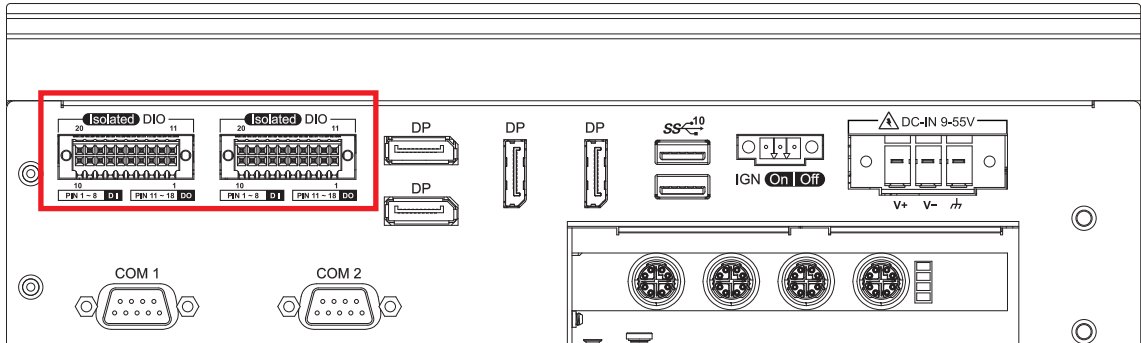

There is a 32-bit (16-bit DI, 16-bit DO) with 2 DIO connectors in the rear side. DI/DO support NPN(sink) and PNP(Source) mode, Each DI channel is equipped with a photocoupler for isolated protection.

Each DO with isolator chip is configured by software for each DIO connector.

DO Safety-Related Certifications:

- 4242-VPK Basic Isolation per DIN V VDE V 0884-10 and DIN EN 61010-1
- 3-KVRMS Isolation for 1 minute per UL 1577
- CSA Component Acceptance Notice 5A, IEC 60950-1 and IEC 61010-1 End Equipment Standards
- GB4943.1-2011 CQC Certified

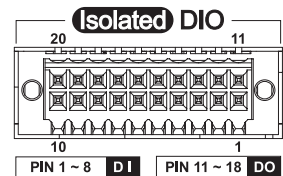

DIO Connectors pin out :

DIO	Pin No.	Definition	Function	Pin No.	Definition	Function
DIO1	1	EXT_IN8	DIO2_GPI0	11	EXT_OUT8	DIO2_GPO0
	2	EXT_IN9	DIO2_GPI1	12	EXT_OUT9	DIO2_GPO1
	3	EXT_IN10	DIO2_GPI2	13	EXT_OUT10	DIO2_GPO2
	4	EXT_IN11	DIO2_GPI3	14	EXT_OUT11	DIO2_GPO3
	5	EXT_IN12	DIO2_GPI4	15	EXT_OUT12	DIO2_GPO4
	6	EXT_IN13	DIO2_GPI5	16	EXT_OUT13	DIO2_GPO5
	7	EXT_IN14	DIO2_GPI6	17	EXT_OUT14	DIO2_GPO6
	8	EXT_IN15	DIO2_GPI7	18	EXT_OUT15	DIO2_GPO7
	9	+VDI_COM1	-	19	GND_ISO_DIO1	-
	10	GND_ISO_DIO1	-	20	+VDIO_EXT1 (6~120V Input)	-

DIO	Pin No.	Definition	Function	Pin No.	Definition	Function
DIO2	1	EXT_IN0	SIO_GPI80	11	EXT_OUT0	SIO_GPO70
	2	EXT_IN1	SIO_GPI81	12	EXT_OUT1	SIO_GPO71
	3	EXT_IN2	SIO_GPI82	13	EXT_OUT2	SIO_GPO72
	4	EXT_IN3	SIO_GPI83	14	EXT_OUT3	SIO_GPO73
	5	EXT_IN4	SIO_GPI84	15	EXT_OUT4	SIO_GPO74
	6	EXT_IN5	SIO_GPI85	16	EXT_OUT5	SIO_GPO75
	7	EXT_IN6	SIO_GPI86	17	EXT_OUT6	SIO_GPO76
	8	EXT_IN7	SIO_GPI87	18	EXT_OUT7	SIO_GPO77
	9	+VDI_COM	-	19	GND_ISO_DIO	-
	10	GND_ISO_DIO	-	20	+VDIO_EXT (6~120V Input)	-

DI Reference Circuit :

Sink Mode (NPN)

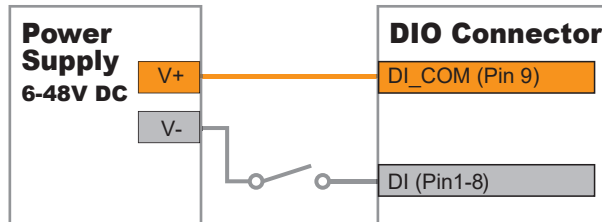

Source Mode (PNP)

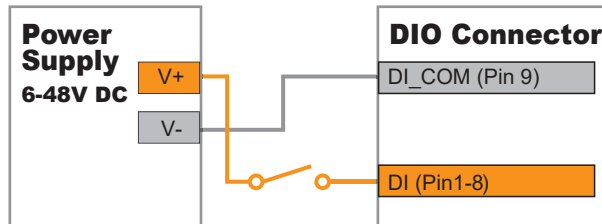

DO Reference Circuit :

Sink Mode
(NPN, Default)

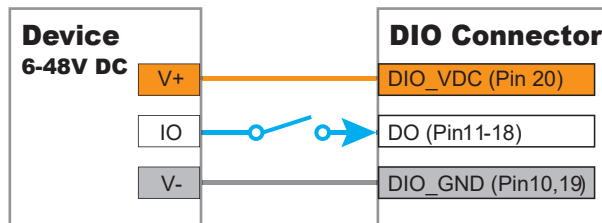

Source Mode
(PNP)

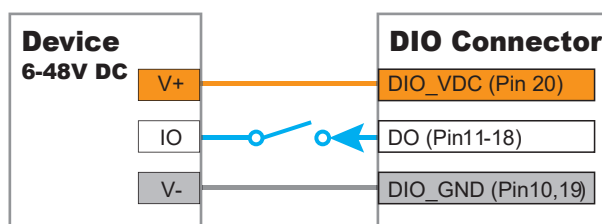

2.4 Main Board Expansion Connectors

2.4.1 EVS-3000 series Main Board Top Side View

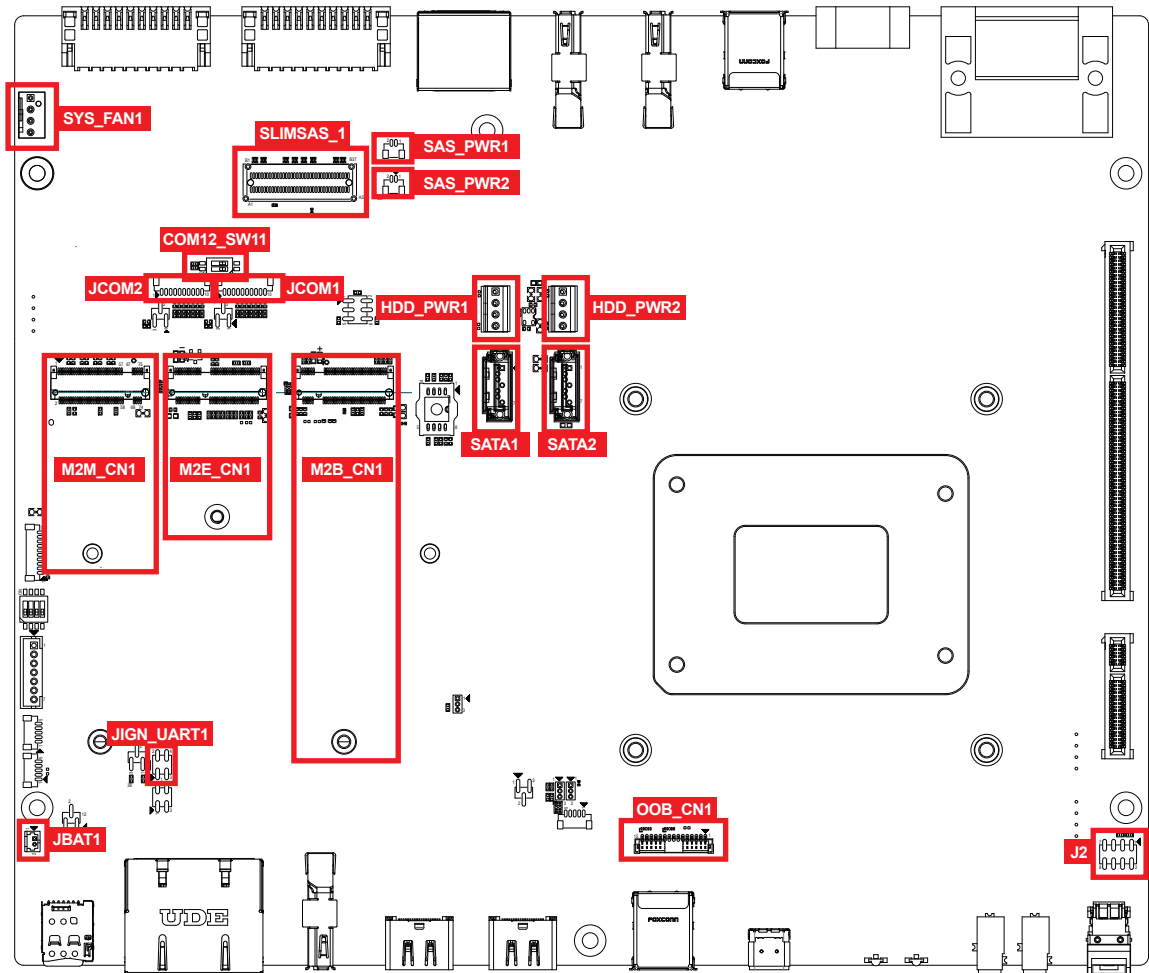

2.4.2 EVS-3000 series Main Board Bottom Side View

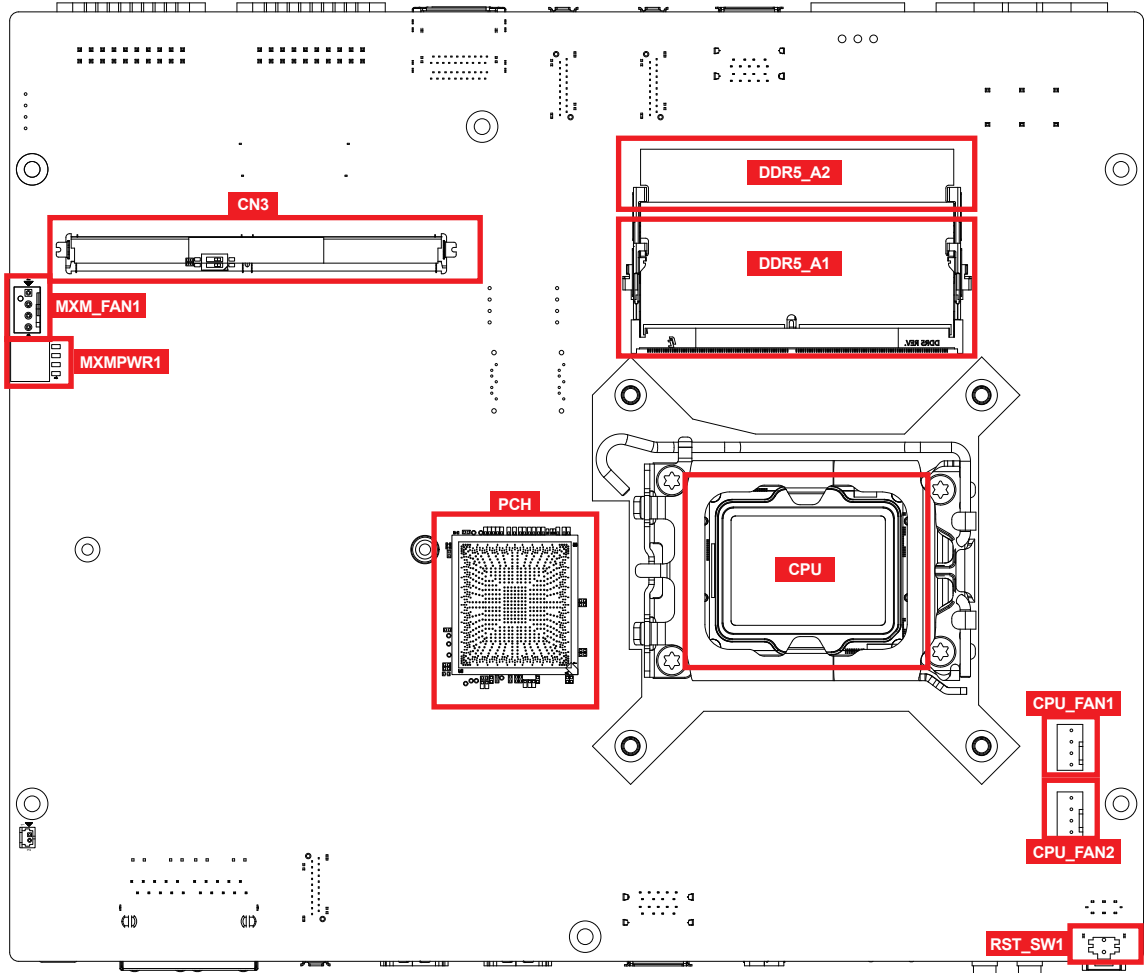

2.4.3 Miscellaneous Pin Header (J2)

2.0mm 2x4p header

This pin header can be used as a backup for following functions, hard drive LED indicator, reset button, power LED indicator, and power-on/off button. The pin assignments of J2 are listed in the following table:

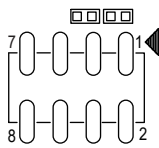
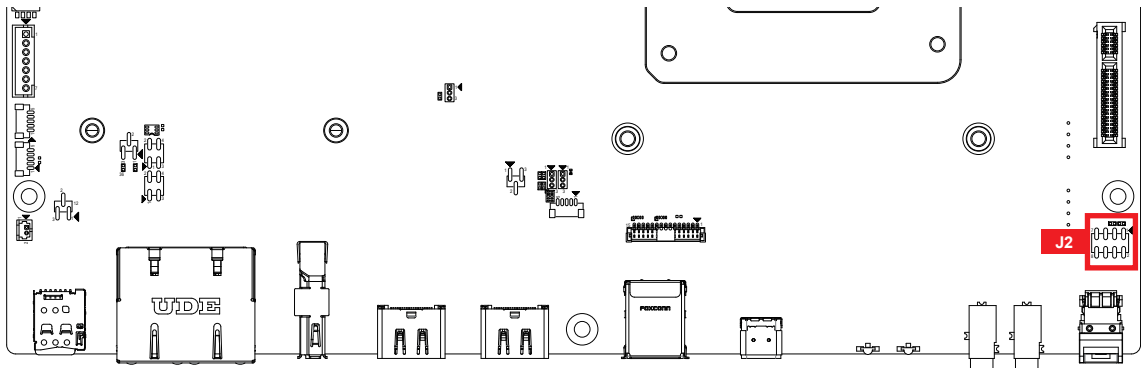

Group	Pin No.	Definition
HDD LED	1	HDD_LED_P
	3	HDD_LED_N
RESET BUTTON	5	FP_RST_BTN_N
	7	Ground
POWER LED	2	PWR_LED_P
	4	PWR_LED_N
POWER BUTTON	6	FP_PWR_BTN_IN
	8	Ground

2.4.4 DDR5 Slot (DDR5_A1/DDR5_A2)

There are 2 DDR5 channel onboard, support DDR5 5600, max 96GB and each channel

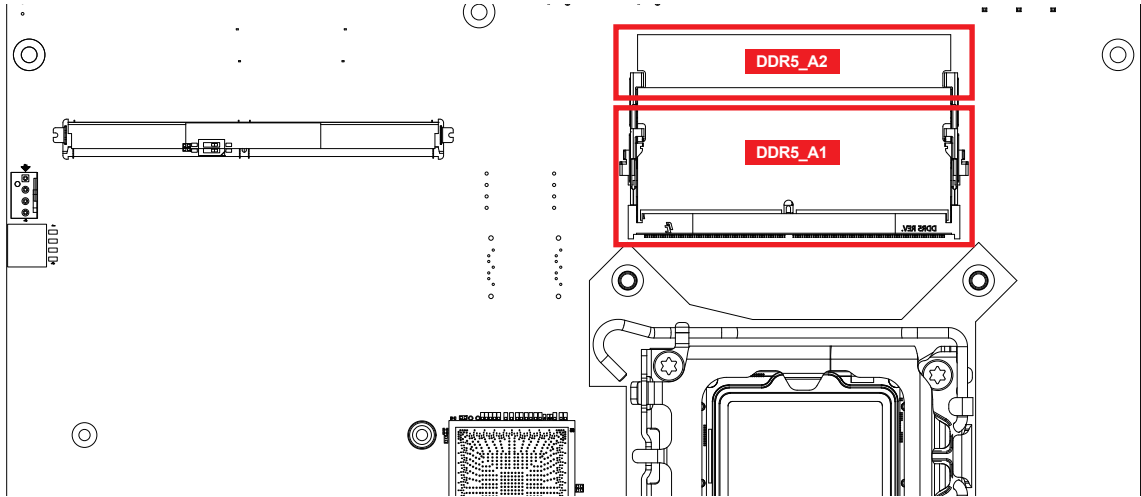

Slot	Description
DDR5_A1	DDR5 Channel A
DDR5_A2	DDR5 Channel B

2.4.5 BIOS Socket (CN1)

If the BIOS need to be changed, please contact the Vecow RMA service team.

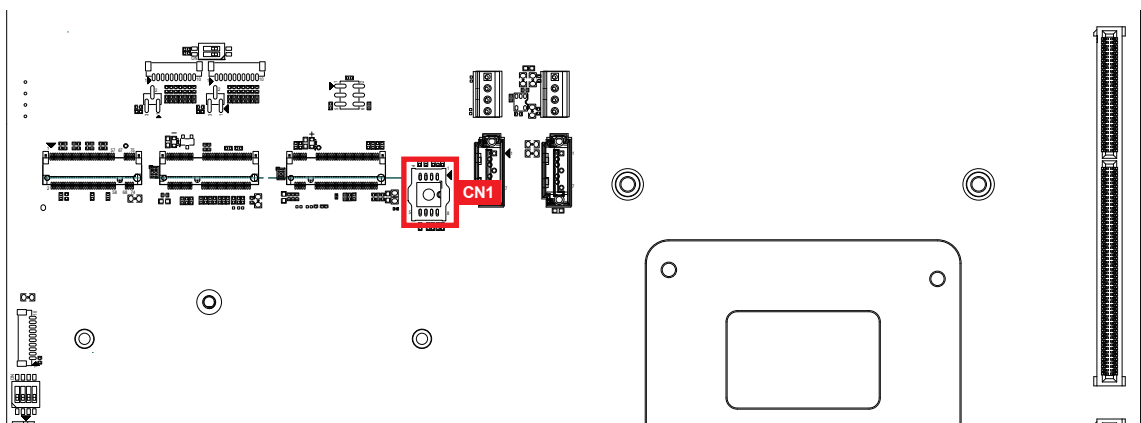

2.4.6 SATA Connector (SATA1/SATA2)

Standard 7 PIN SATA Connector

There are 2 onboard high performance Serial ATA III. It supports higher storage capacity with less cabling effort and smaller required space.

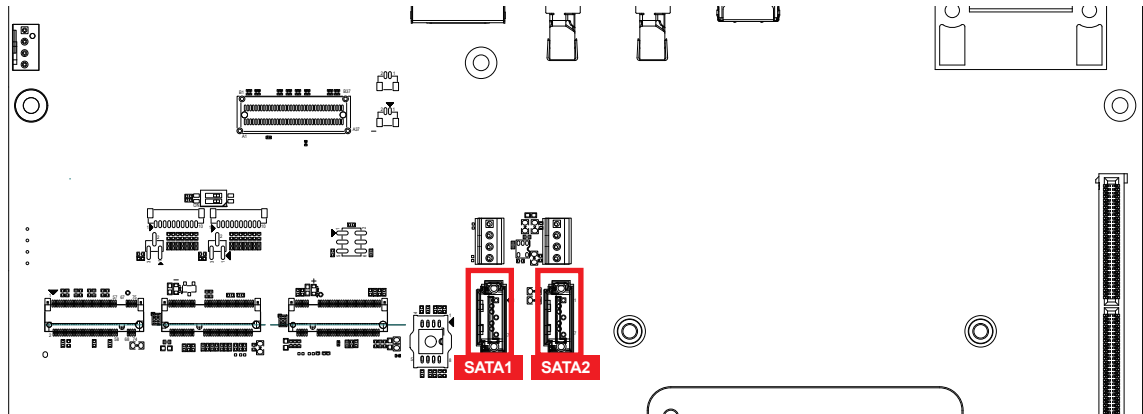

Pin No.	Description	Pin No.	Description
1	Ground	5	RX DN
2	TX DP	6	RX DP
3	TX DN	7	Ground
4	Ground		

2.4.7 SATA Power Header (HDD_PWR1/HDD_PWR2)

The EVS-3000 series is also equipped with two SATA power connectors. It supports 5V (Up to 2A) and 12V (Up to 2A) currents to the hard drive or SSD. The pin assignments of HDD_PWR1 , HDD_PWR2 are listed in the following table:

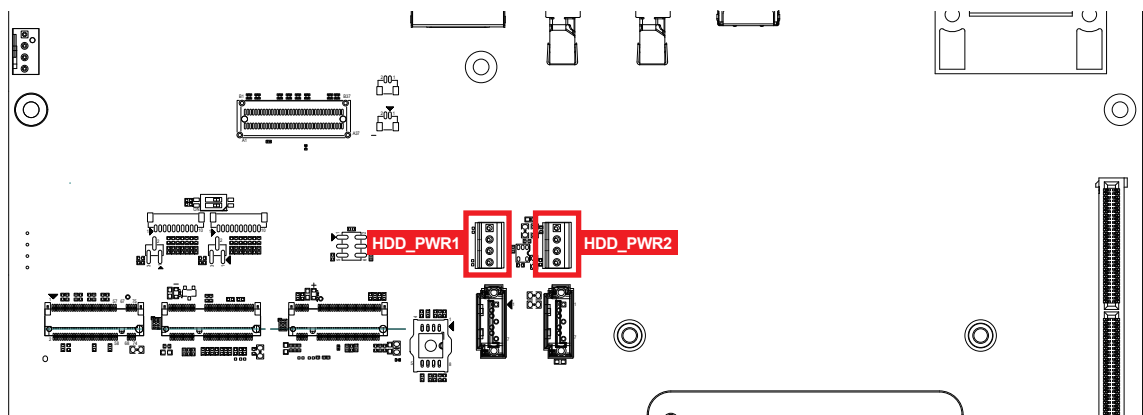

Pin No.	Description	Pin No.	Description
1	+V12 (Max. 2A)	2	Ground
3	Ground	4	+V5 (Max. 2A)

2.4.8 ESPI port Header(DEBUG1)

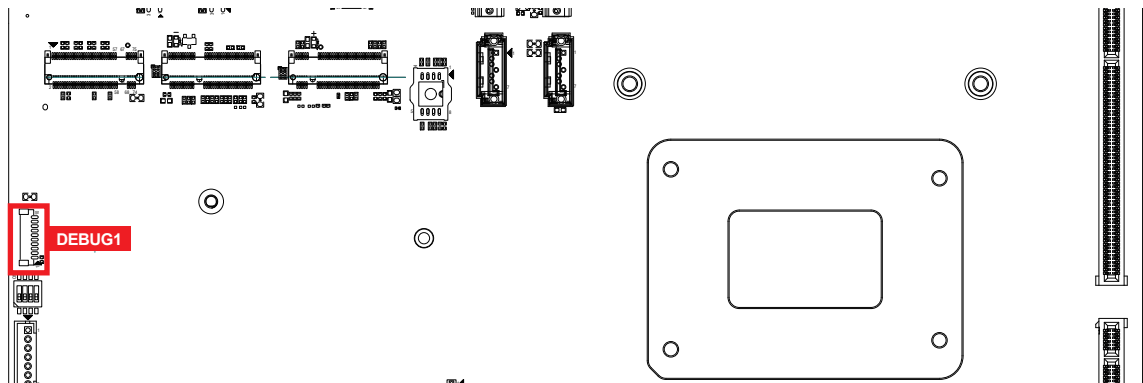

This pin header is through by ESPI interface and pins define are listed in the following table

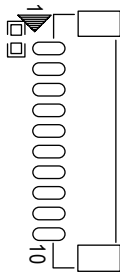

Pin No.	Pin Name	Pin No.	Pin Name
1	+V3.3S	6	Port 80_ESPI_IO3
2	Port 80_ESPI_CS#	7	GND
3	Port 80_ESPI_IO0	8	Port 80_ESPI_CLK
4	Port 80_ESPI_IO1	9	RST 80_ESPI_RST#
5	Port 80_ESPI_IO2	10	GND

2.4.9 M2D Board PCIE cable connector:SLIMSAS_1

EVS-3000 series support front access M.2 tray via cable to connect to ECX-3000 M2D Board

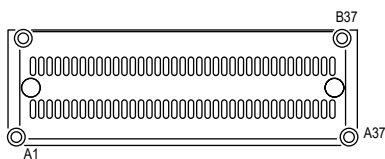
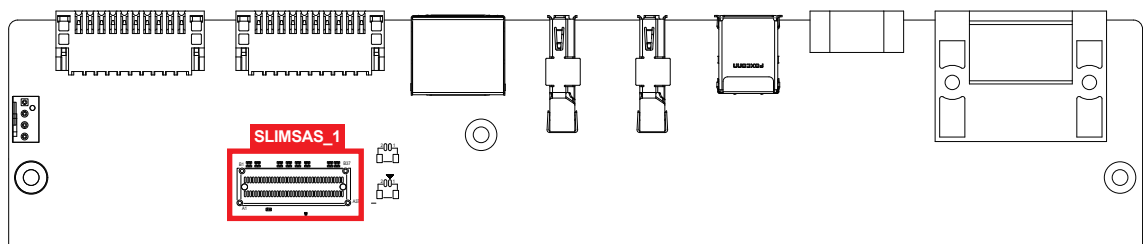

Location	PCIE
SLIMSAS_1	PCH PCIe4
	PCH PCIe4

2.4.10 M2D Board Power cable Connector:SAS_PWR1,SAS_PWR2

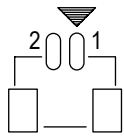
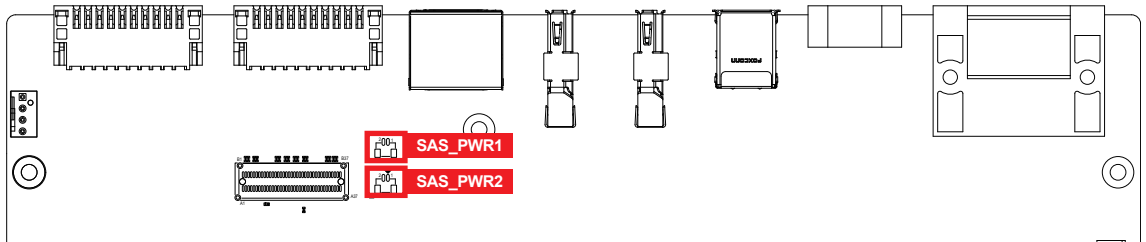

Pin NO.	Definition
1	12V
2	GND

2.4.11 RTC Battery(JBAT1)

The system's real-time clock is powered by a lithium battery. It is Equipped with Panasonic BR2032 190mAh lithium battery. It is recommended that you not replace the lithium battery on your own. If the battery needs to be changed, please contact the Vecow RMA service team.

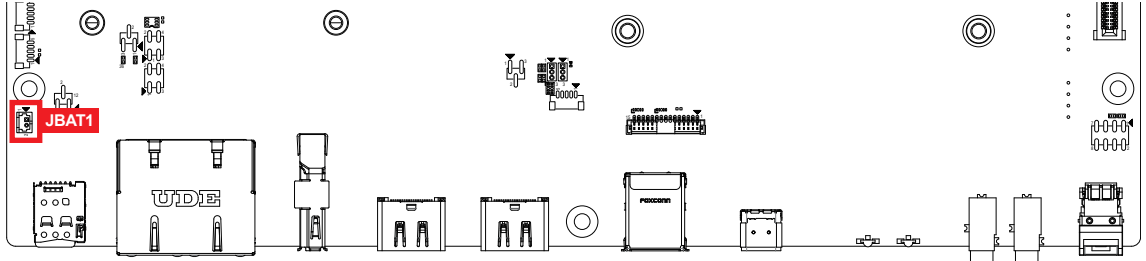

2.4.12 FAN CONNECTOR(CPU_FAN1 /CPU_FAN2/MXM_FAN1/SYS_FAN1)

Fan power connector supports for additional thermal requirements. The pin assignments of CPU_FAN1,CPU_FAN2,MXM_FAN1 and SYS_FAN1 are listed in the following table

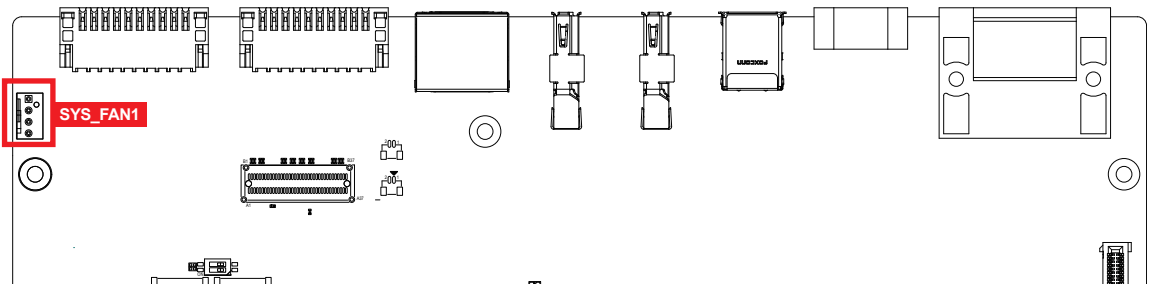

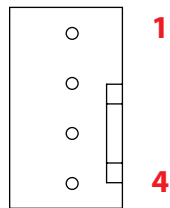
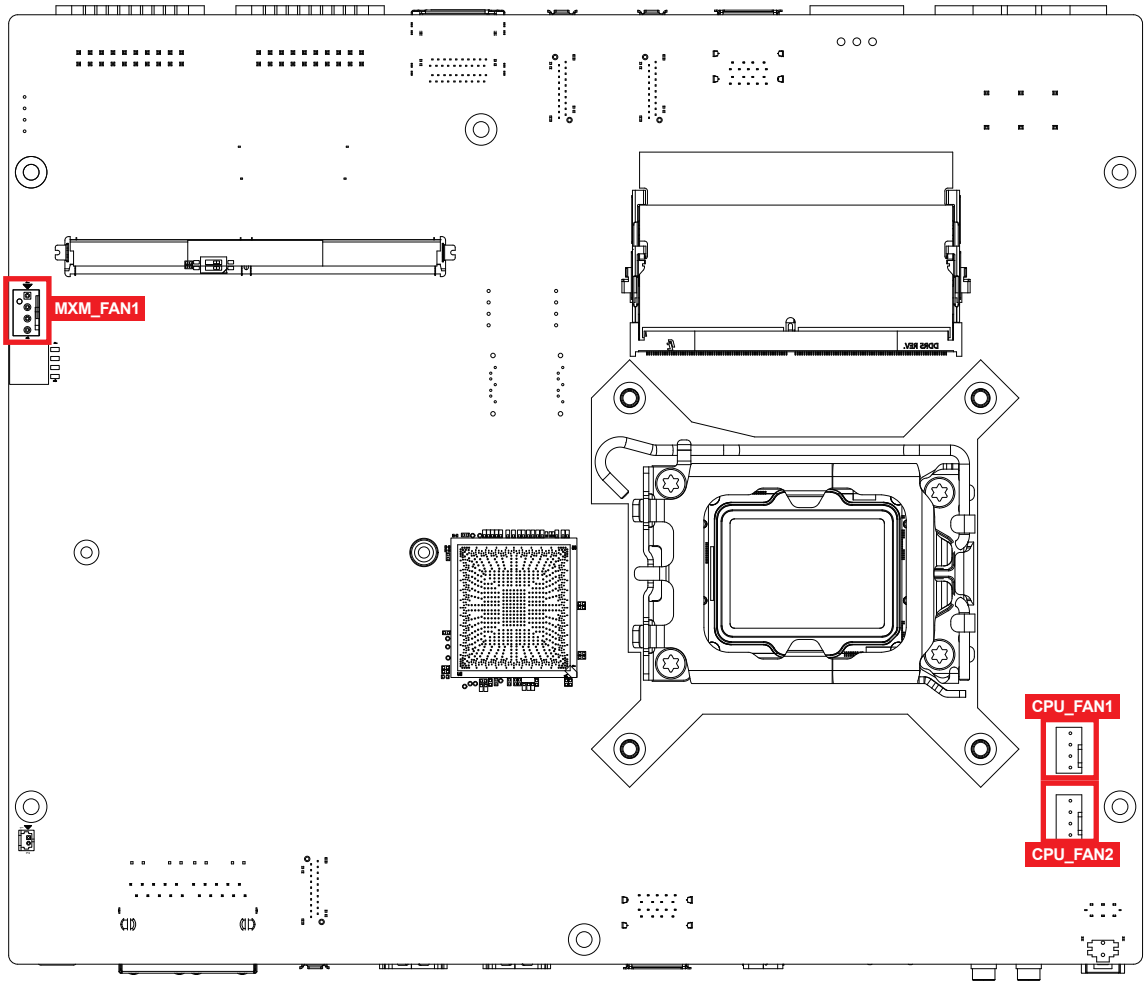

Pin Number	Function
1	GND
2	+12V (2A max)
3	Fan speed sensor
4	Fan PWM

2.4.13 MXM POWER(MXMPWR1)

This connector provides +12V for MXM Graphic card only and the pin define are listed in the following table.

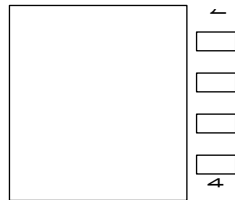
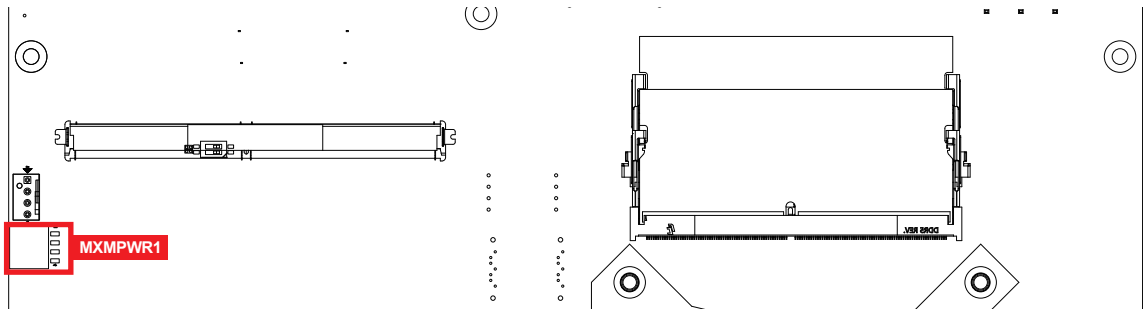

Pin Number	Function
1	GND
2	GND
3	12V
4	12V

2.4.14 COM Port (JCOM1-JCOM2)

EVS-3000 series provides 2 serial ports (JCOM1-JCOM2) headers for internal COM port cable and the pin define are listed in the following table

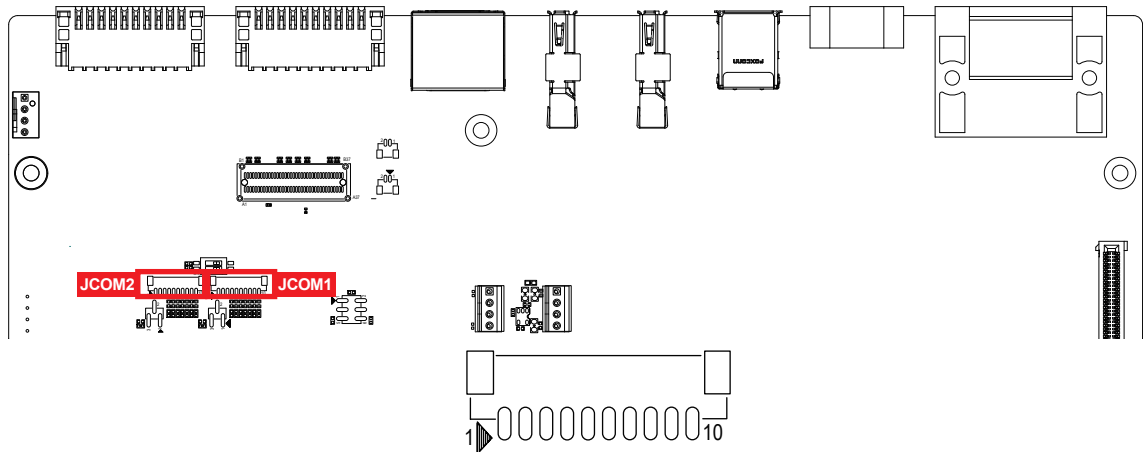

Pin No.	Description	Pin No.	Description
1	NC	6	TXD
2	Ground	7	RTS
3	RI	8	RXD
4	DTR	9	DSR
5	CTS	10	DCD

2.4.15 M.2 key E Slot for USB2.0, PCIe Gen4x1 support (M2E_CN1)

USB 2.0/PCIe x1

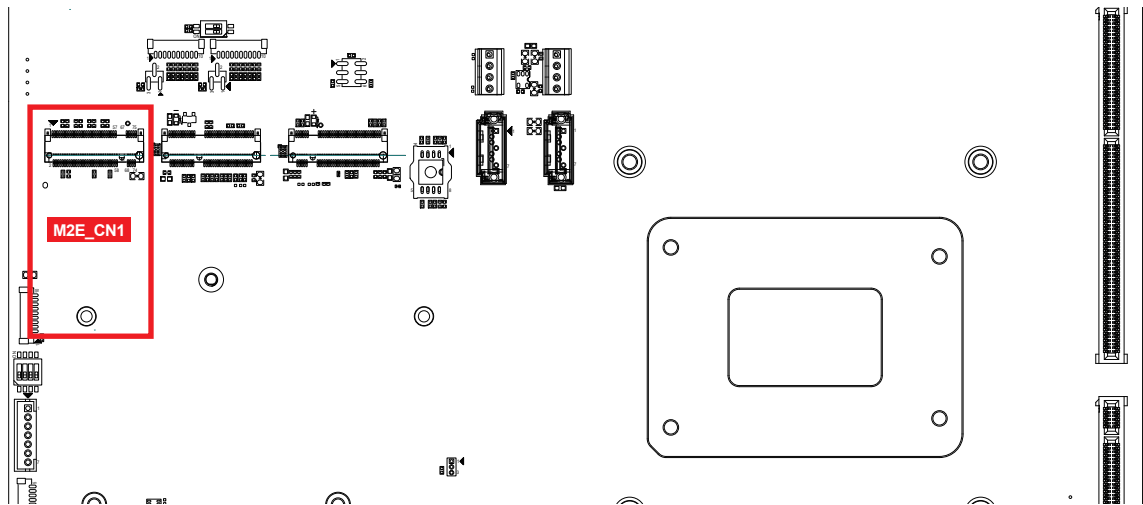

M.2 KEY E: USB2.0/PCIex1 M.2 key E connector is suitable for applications that use wireless connectivity including Wi-Fi, Bluetooth, NFC or GNSS. Module card types include 2230

Pin Out :

Pin No.	Description	Pin No.	Description
75	GND	74	+V3.3_AUX
73	NC	72	+V3.3_AUX
71	NC	70	NC
69	GND	68	PCIE_CLK_REQ#
67	NC	66	NC
65	NC	64	M2E_REFCLK
63	GND	62	SMB_ALERT#
61	NC	60	SMB_CLK
59	NC	58	SMB_DATA
57	GND	56	M2E_WLAN_DISABLE
55	PCIE_WAKE#	54	M2E_BT_DISABLE
53	PCIE_CLK_REQ0#	52	PLTRST#
51	GND	50	SUS_CLK
49	PCIE_100M_CLK__N	48	NC
47	PCIE_100M_CLK__P	46	NC
45	GND	44	CNVI_BLANKING
43	PCIE_RX_N	42	CL_CLK
41	PCIE_RX_P	40	CL_DATA
39	GND	38	CL_RST_N

Pin No.	Description	Pin No.	Description
37	PCIE_TX_N	36	NC
35	PCIE_TX_P	34	NC
33	GND	32	NC
Mechanical Key			
23	NC		
21	NC	22	NC
19	GND	20	NC
17	NC	18	GND
15	NC	16	LED2#
13	GND	14	NC
11	NC	12	NC
9	NC	10	NC
7	GND	8	NC
5	USB-	6	LED1#
3	USB+	4	+V3.3_AUX
1	GND	2	+V3.3_AUX

2.4.16 M.2 key M Slot for PCIe Gen4 x4 support (M2M_CN1)

M.2 key M connector is suitable for applications that use Host I/Fs supported by either PCIe Module card types include 2280 (Only Support PCIe x4)

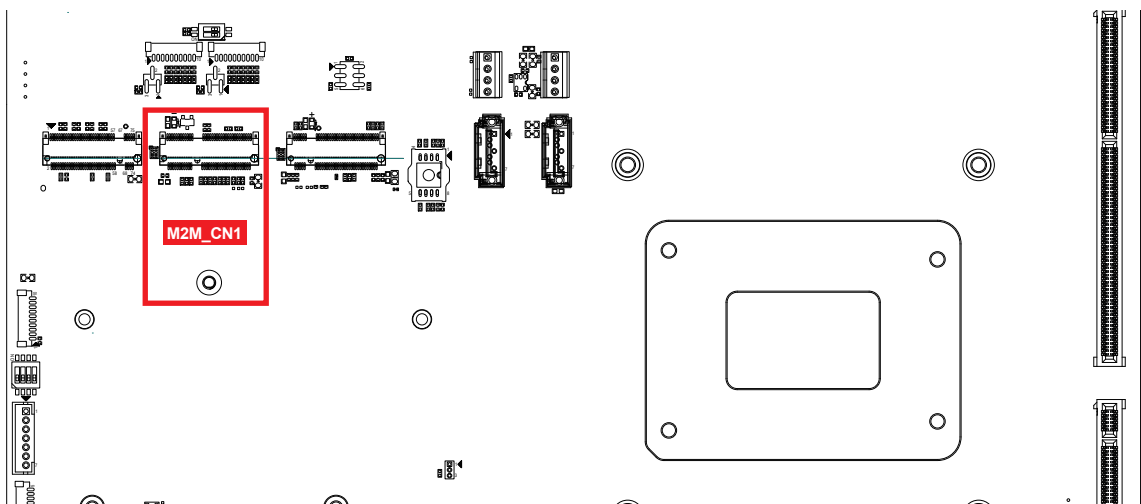

Pin Out :

Pin No.	Description	Pin No.	Description
75	Ground		
73	Ground	74	3.3V
71	Ground	72	3.3V
69	PEDET	70	3.3V
67	Ground	68	NC
Mechanical Key			
57	Ground	58	NC
55	REFCLKp	56	NC
53	REFCLKn	54	PEWAKE#
51	Ground	52	CLKREQ#
49	PETp0/SATA_A+	50	PERST#
47	PETn0/SATA_A-	48	NC
45	Ground	46	NC
43	PERp0/SATA_B-	44	NC
41	PERn0/SATA_B+	42	NC
39	Ground	40	NC
37	PETp1	38	DEVSLP
35	PETn1	36	NC
33	Ground	34	NC
31	PERp1	32	NC
29	PERn1	30	NC
27	Ground	28	NC
25	PETp2	26	NC
23	PETn2	24	NC
21	Ground	22	NC
19	PERp2	20	NC
17	PERn2	18	3.3V
15	Ground	16	3.3V
13	PETp3	14	3.3V
11	PETn3	12	3.3V
9	Ground	10	LED1#
7	PERp3	8	NC
5	PERn3	6	NC
3	Ground	4	3.3V
1	Ground	2	3.3V

2.4.17 M.2 KEY B USB3,USB2,PCIe,SATA Support (M2B_CN1)

M.2 KEY-B support USB3.2/USB2.0,SATA and PCIe x1, if you want to change to USB3.2 or SATA or PCIe x1, you can find the setting in BIOS.Module card types include 3052,2280. (Remind: The default BIOS setting is M.2 Key B for USB3.2. If wanting to use PCIe or SATA, an optional BIOS is required.)

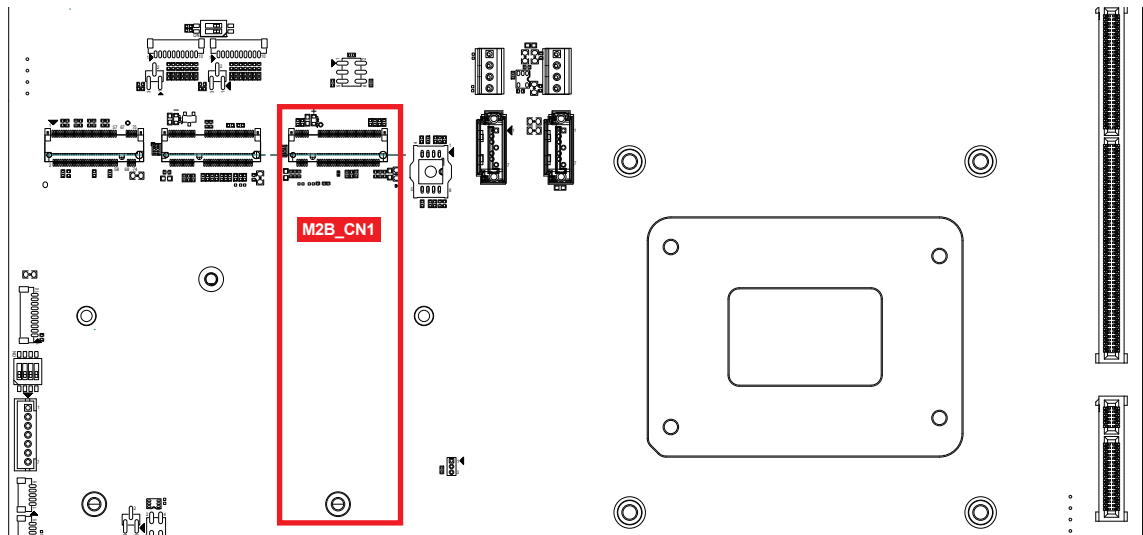

Pin Out :

Pin No.	Description	Pin No.	Description
75	NC	74	+V3.3A
73	GND	72	+V3.3A
71	GND	70	+V3.3A
69	NC	68	NC
67	NC	66	SIM_DETECT
65	NC	64	NC
63	NC	62	NC
61	NC	60	NC
59	NC	58	NC
57	GND	56	NC
55	PCIE_100M_CLK_P	54	PCIE_WAKE#
53	PCIE_100M_CLK_N	52	PCIE_CLK_REQ
51	GND	50	PLTRST#
49	SATA_RXN2, PCIe_TX_1P	48	NC
47	SATA_RXP2, PCIe_TX_1N	46	NC
45	GND	44	NC

Pin No.	Description	Pin No.	Description
43	SATA_TXP2, PCIe_RX_1P	42	NC
41	SATA_TXN2, PCIe_RX_1N	40	NC
39	GND	38	DEVSLP
37	(default)USB_TX_2P, PCIe_TX_2P	36	UIM_PWR
35	(default)USB_TX_2N, PCIe_TX_2N	34	UIM_DATA
33	GND	32	UIM_CLK
31	(default)USB_RX_2P, PCIe_RX_2P	30	UIM_RESET
29	(default)USB_RX_2N, PCIe_RX_2N	28	NC
27	GND	26	NC
25	NC	24	NC
23	NC	22	NC
21	NC	20	NC
Mechanical Key			
11	GND		
9	USB-	10	LED1#
7	USB+	8	NC
5	GND	6	FULL_CARD_PWR_OFF
3	GND	4	+V3.3A
1	NC	2	+V3.3A

2.4.18 Detect battery capacity (J1)

Detect battery capacity for superCAP module.

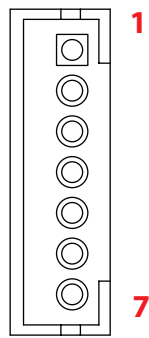
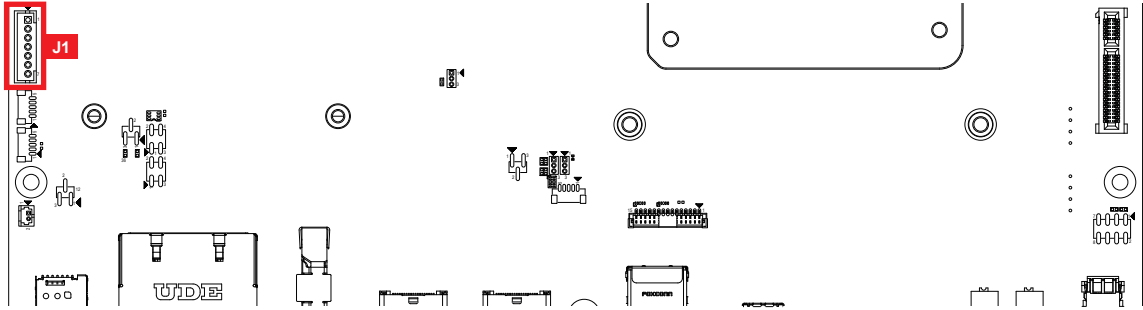

Pin Number	Function
1	GND
2	SMB_DATA
3	SMB_CLK
4	NC
5	NC
6	SC_INTVCC
7	VBAT_RATE

2.4.19 IGNITION FW Programming Header(JIGN_UART1)

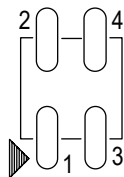
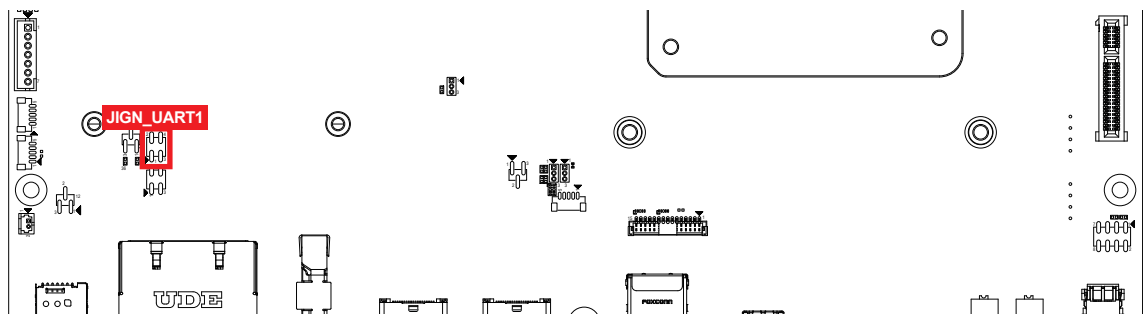

Pin No.	Definition
1	GND
2	UART_TX
3	+V3.3
4	UART_RX

2.5 Main Board Jumper Settings

2.5.1 Board Top View of EVS-3000 Main Board with Jumper and DIP Switch

The figure below is the top view of EVS-3000 series main board which is the main board. It shows the location of the jumpers and the switches.

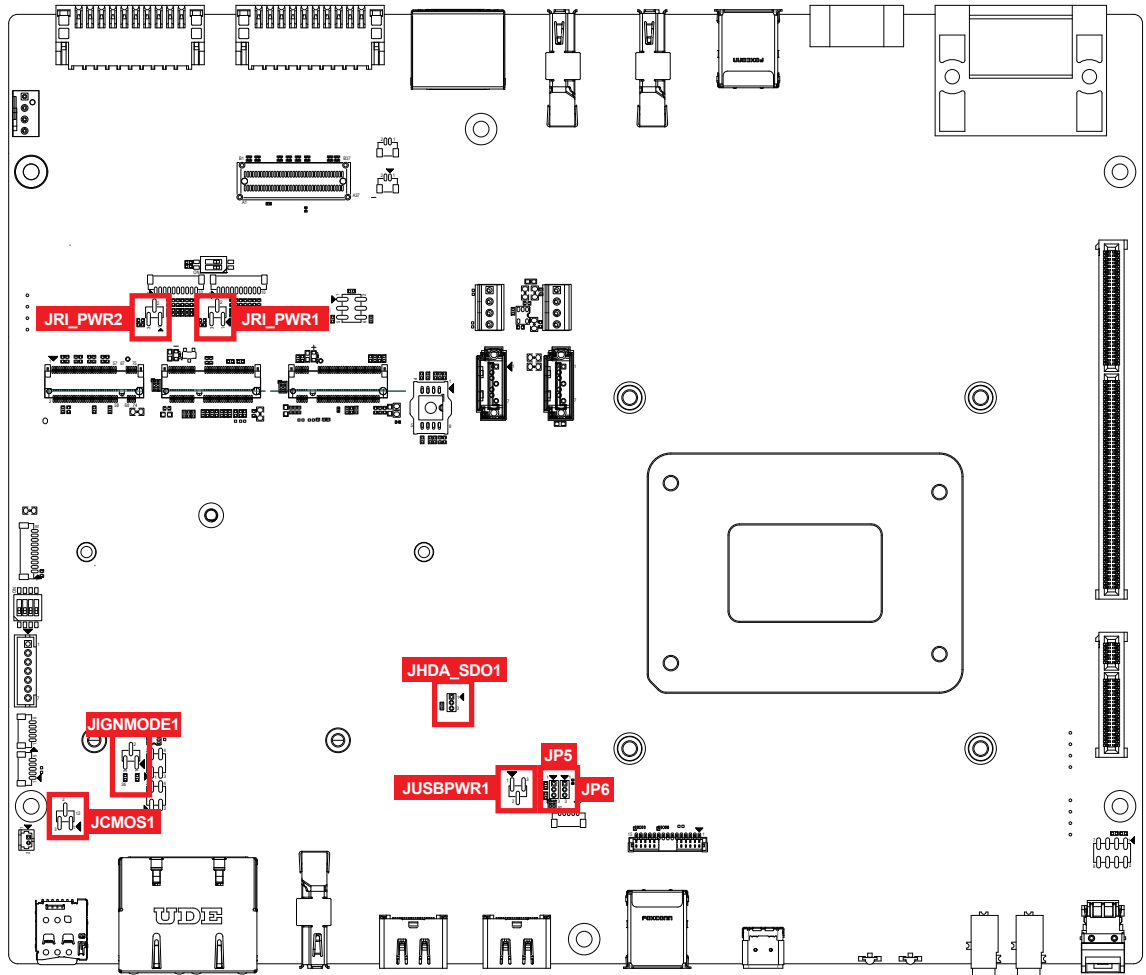

You may configure your card to match the needs of your application by setting jumpers. A jumper is a metal bridge used to close an electric circuit. It consists of two metal pins and a small metal clip (often protected by a plastic cover) that slides over the pins to connect them. To "close" a jumper, you connect the pins with the clip. To "open" a jumper, you remove the clip. Sometimes a jumper will have three pins, labeled 1, 2 and 3. In this case you would connect either pins 1 and 2, or 2 and 3.

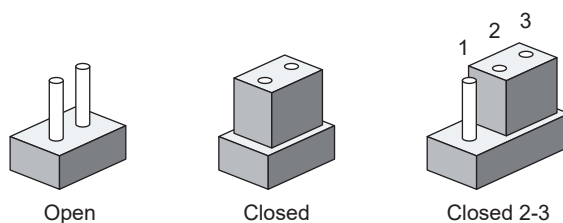

You may configure your card to match the needs of your application by DIP switch. As below show the DIP switch on and off.

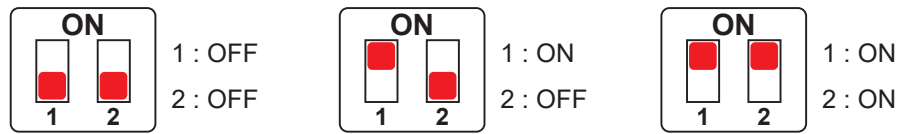

2.5.2 USB Power Jumper (JUSBPWR1)

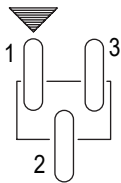
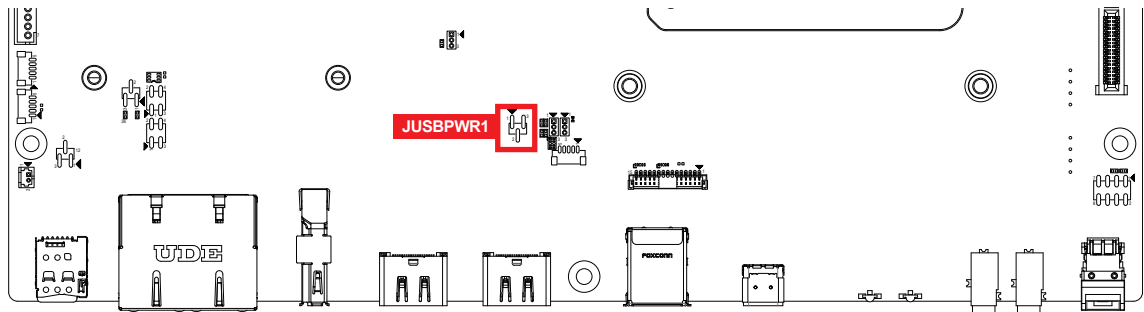

Jumper	Setting	Function
JUSBPWR1	1-2	Supported Wake Up (Default)
	2-3	Non Wake Up support

2.5.3 COM Port RI Pin Select (JRI_PWR1/JRI_PWR2)

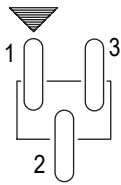
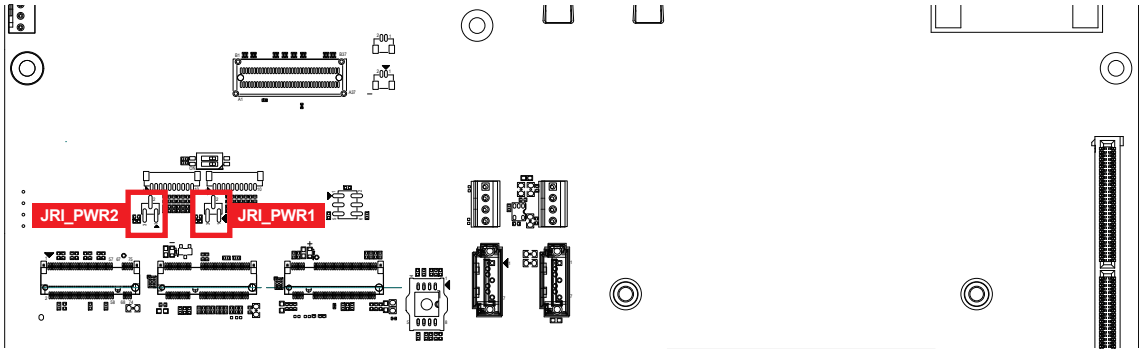

Pin Header	Pin No.	Description
JRI_PWR1	1 - 2	+12V (1A max.)
JRI_PWR2	2 - 3	Non Wake Up support (Default)

2.5.4 CPU PEG Configuration(JP5/JP6)

JP5/JP6 configuration table as follows:

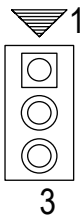
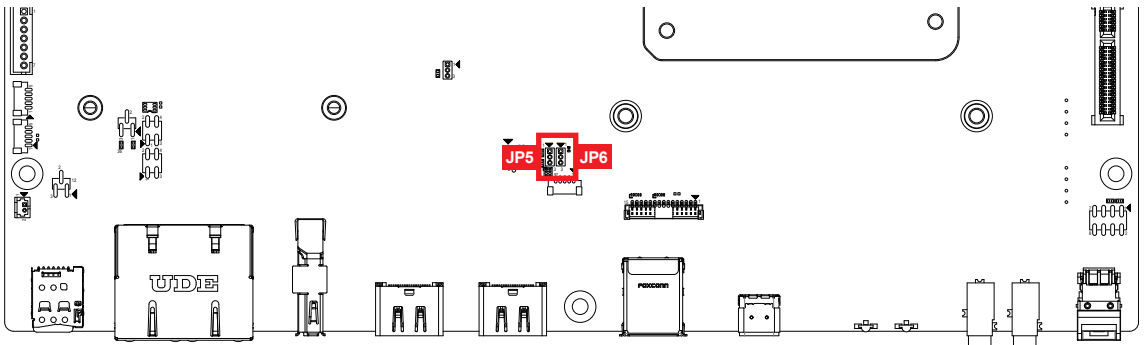

PCIe Configuration	JP5	JP6
2 x 8(Default)	1-2	2-3
1 x16	2-3	2-3

2.5.5 Clear CMOS(JCMOS1)

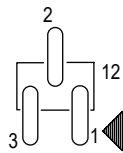
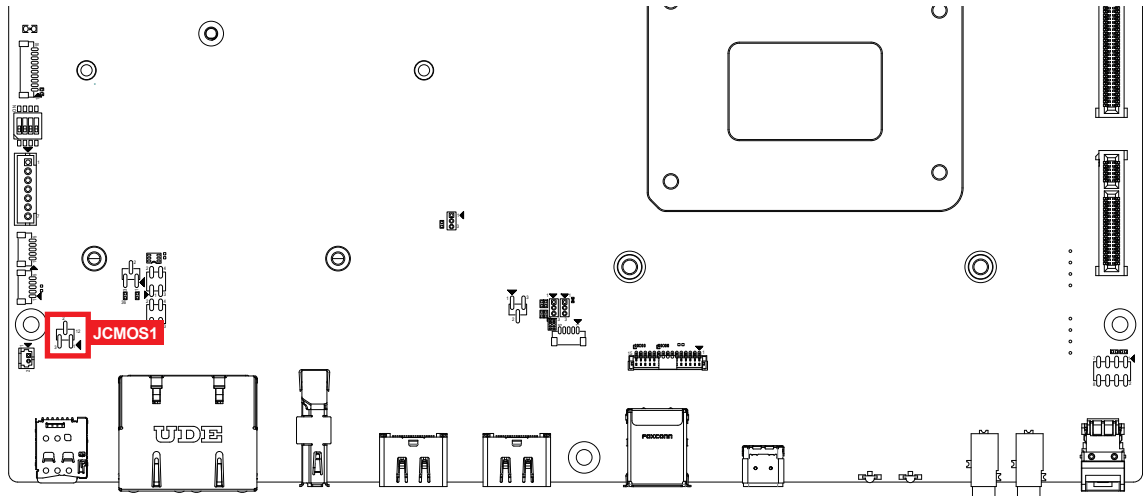

Jumper	Setting	Function
JCMOS1	1 : 2	*Normal (Default)
	2 : 3	Clear CMOS

2.5.6 HDA_SDO1(JHDA_SDO1)

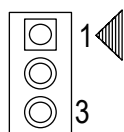
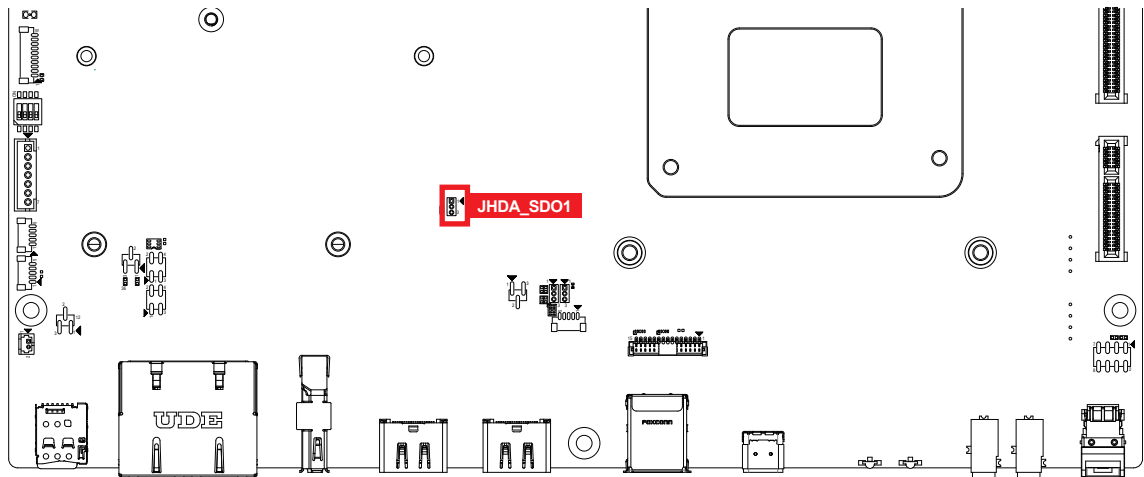

Jumper	Setting	Function
JHDA_SDO1	1 : 2	*Enable security measures defined in the Flash Descriptor. (Default)
	2 : 3	Disable Flash Descriptor Security (override)

2.5.7 Ignition Mode (JIGNMODE1)

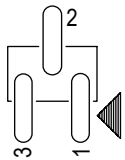
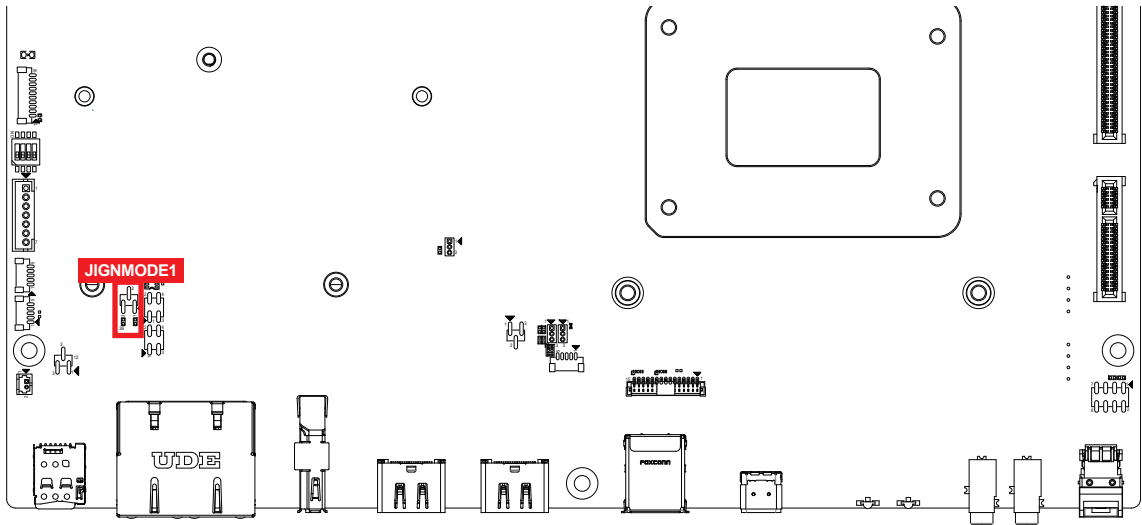

Jumper	Setting	Function
JIGNMODE1	1 : 2	H/W mode
	2 : 3	S/W mode (default)

2.5.8 RS-485/422 RECEIVER TERMINATION RESISTANCE(COM12_SW1)

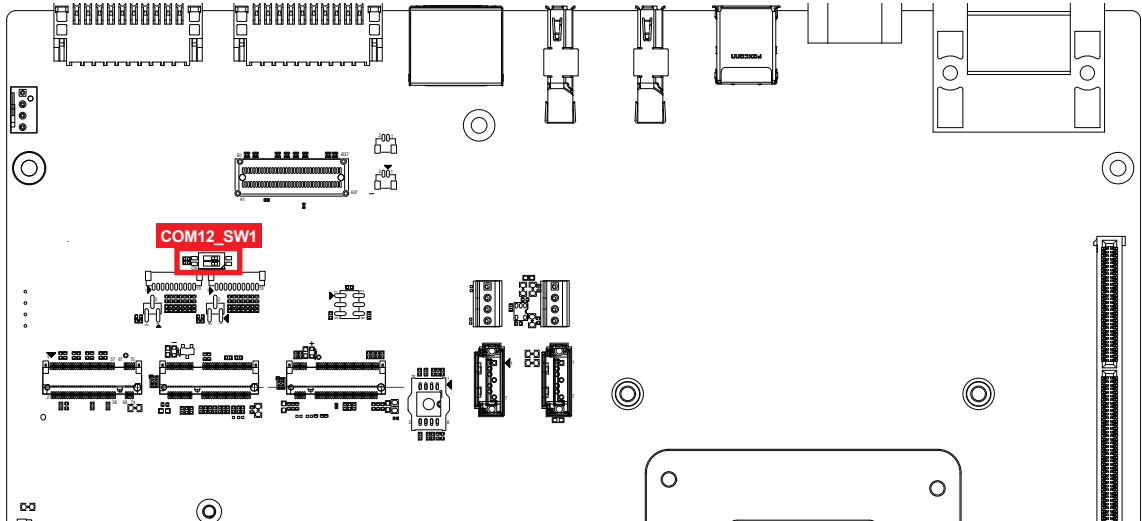

Ports	Location	Setting	Function
COM1	COM12_SW1	3(ON)	DCD / RXD Termination 120R enable
		1(OFF)	DCD / RXD Termination 120R Disable(default)
4(ON)		DCD / RXD Termination 120R enable	
2(OFF)		DCD / RXD Termination 120R Disable(default)	





2.6 Ignition Control

EVS-3000 series provides ignition power control feature for in-vehicle applications. The built-in MCU monitors the ignition signal and turns on/off the system according to pre-defined on/off delay period.

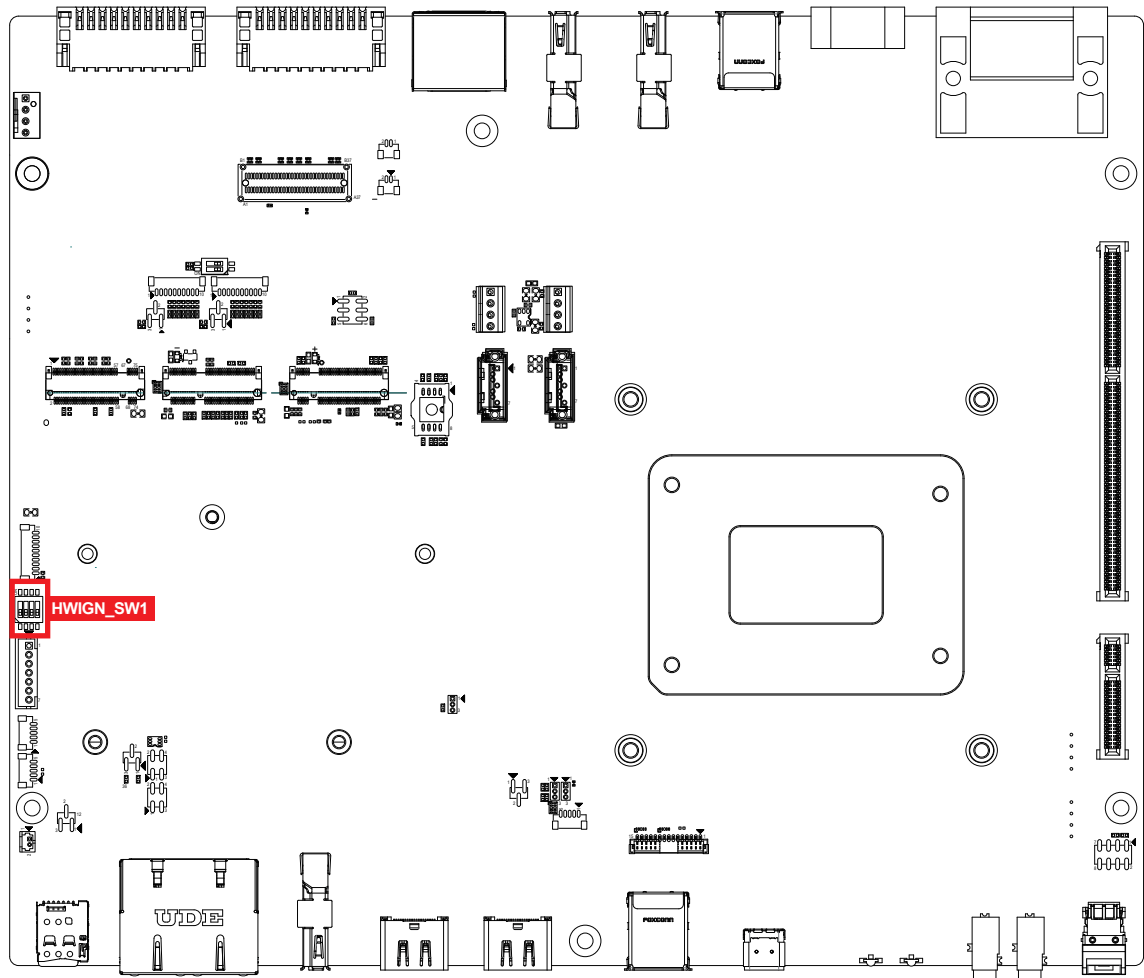
2.6.1 Adjust Ignition Control Modes

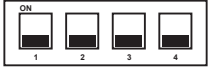
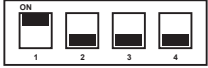
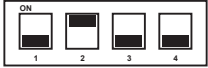
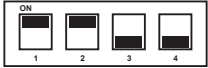
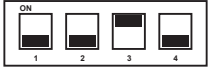
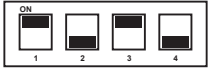
EVS-3000 series provides 16 modes of different power on/off delay periods adjustable via HWIGN_SW1 switch. The default rotary switch is set to 0 in ATX/AT power mode.

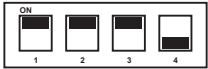
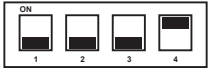
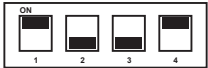
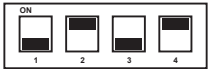
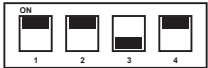

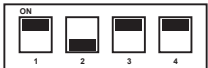
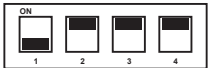
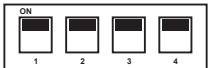
Item	Power On Delay	Power Off Delay	Switch Position
0	ATX/AT mode (Default)		
1	No delay	No delay	
2	No delay	5 seconds	
3	No delay	10 seconds	
4	No delay	20 seconds	
5	5 seconds	30 seconds	
6	5 seconds	60 seconds	
7	5 seconds	90 seconds	
8	5 seconds	30 minutes	
9	5 seconds	1 hour	
A	10 seconds	2 hours	
B	10 seconds	4 hours	
C	10 seconds	6 hours	
D	10 seconds	8 hours	
E	10 seconds	12 hours	
F	10 seconds	24 hours	

2.6.2 Ignition Control Wiring

To activate ignition control, you need to provide IGN signal via the 3-pin pluggable terminal block located in the back panel. Please find below the general wiring configuration.

Pin No.	Definition
1	Ignition (IGN)
2	SW+
3	SW-

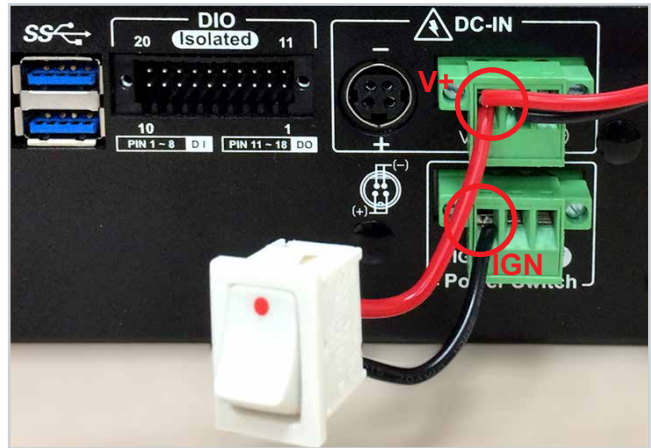

For testing purpose, you can refer to the picture below to simulate ignition signal input controlled by a latching switch.

Note :

1. DC power source and IGN share the same ground.
2. EVS-3000 series supports 9V to 55V wide range DC power input in ATX/AT mode. In Ignition mode, the input voltage is fixed to 12V/24V for car battery scenario.
3. For proper ignition control, the power button setting should be "Power Down" mode.

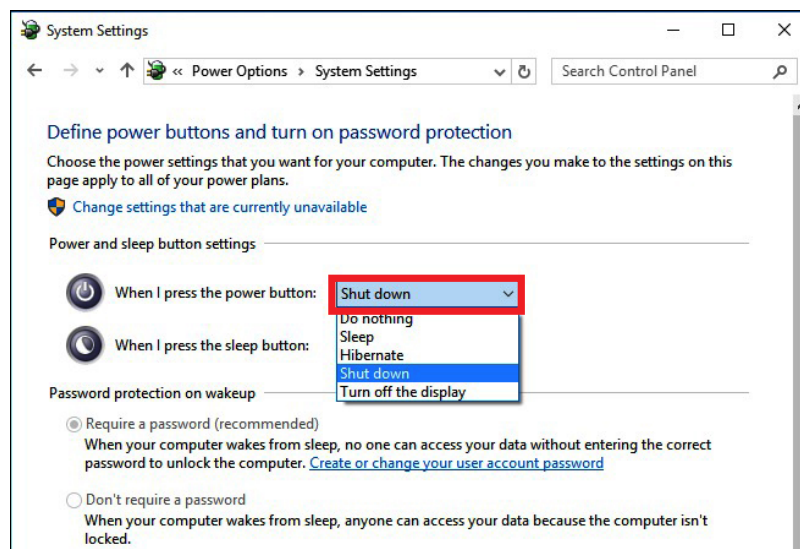

In Windows for example, you need to set "When I press the power button" to Shut down.

3

SYSTEM SETUP

3.1 How to Open Your EVS-3000

Step 1 Remove one F-M3x4L screw.

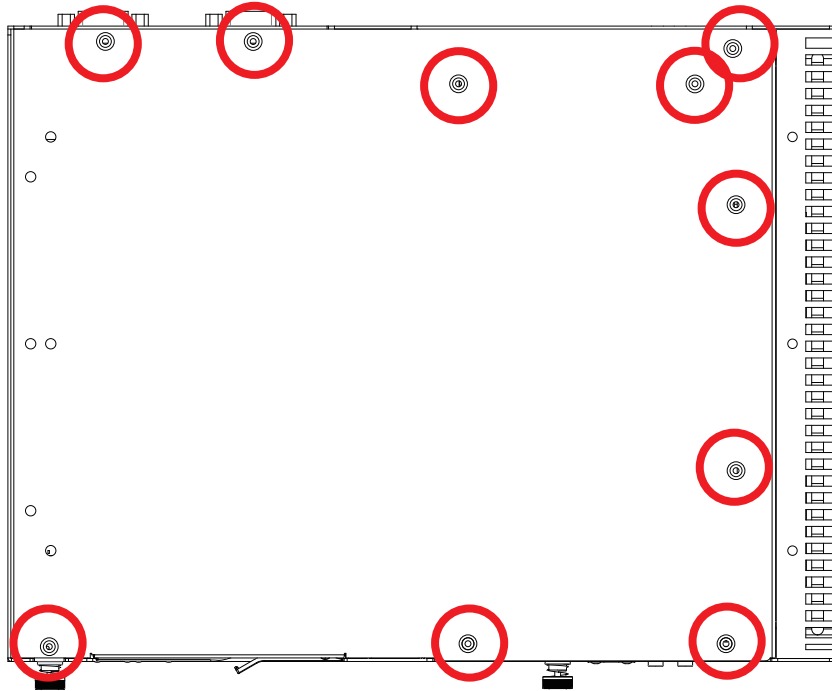

Step 2 Remove the bottom cover.

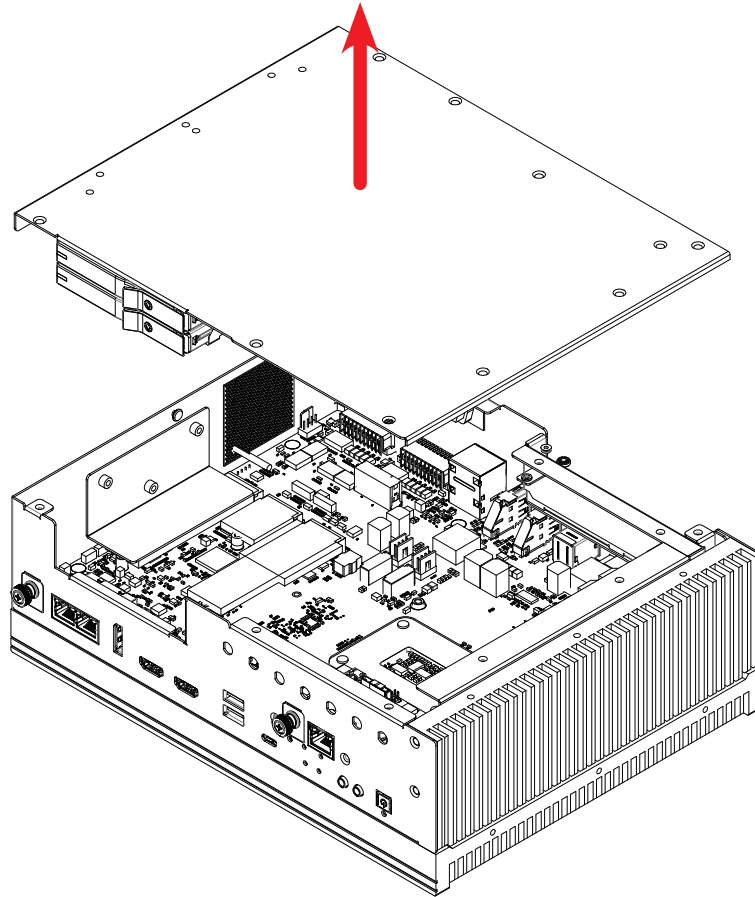

3.2 Installing CPU

Step 1 Open the Heat Sink.

EVS-3000

Step 1-1 Remove six P-M3x6L screws (Red), And Remove Four P-M3x16L screws (Orange).

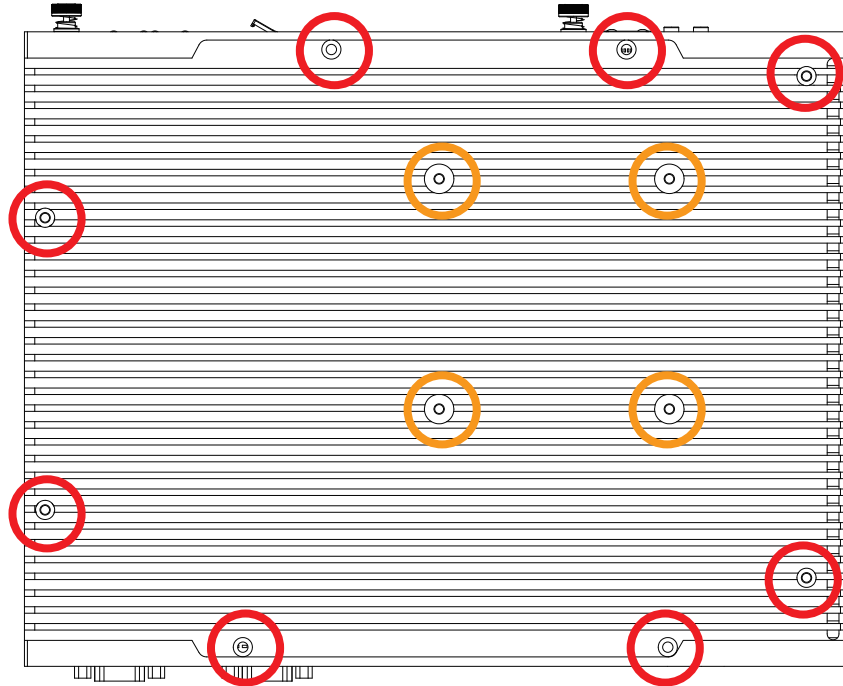

EVS-3000F

Step 1-1 Remove six P-M3x6L screws (Red), And Remove Four F-M3x4L screws (Orange).

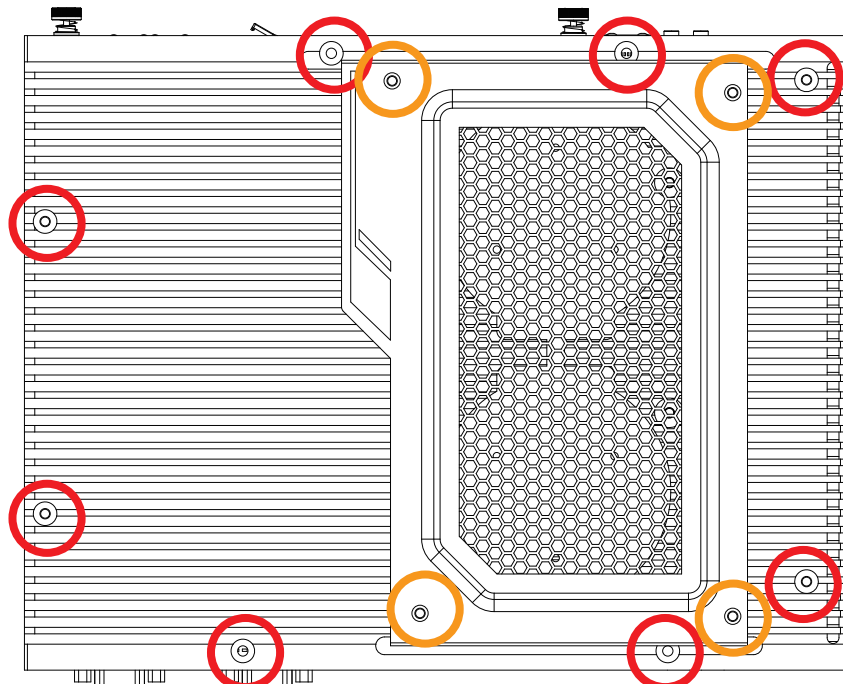

Step 1-2 Remove the sink, And Remove Four P-M3x16L screws.

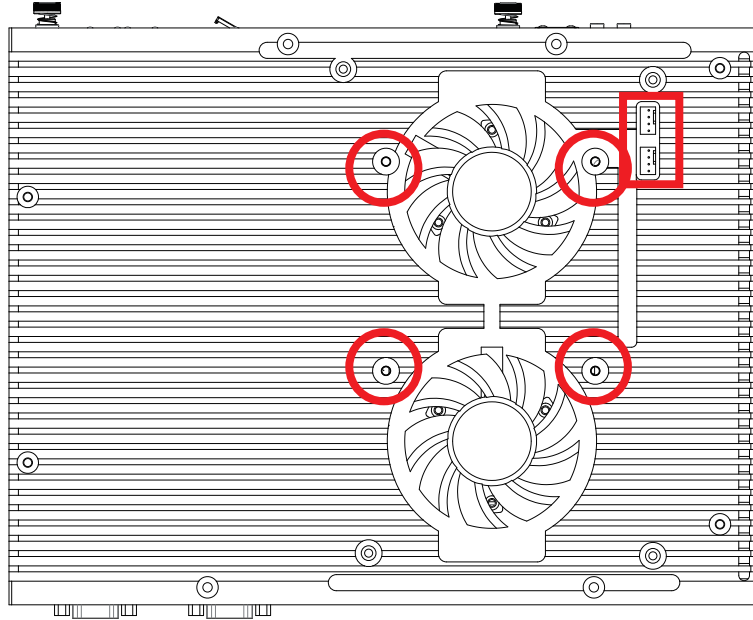

Step 2 Remove the sink.
EVS-3000

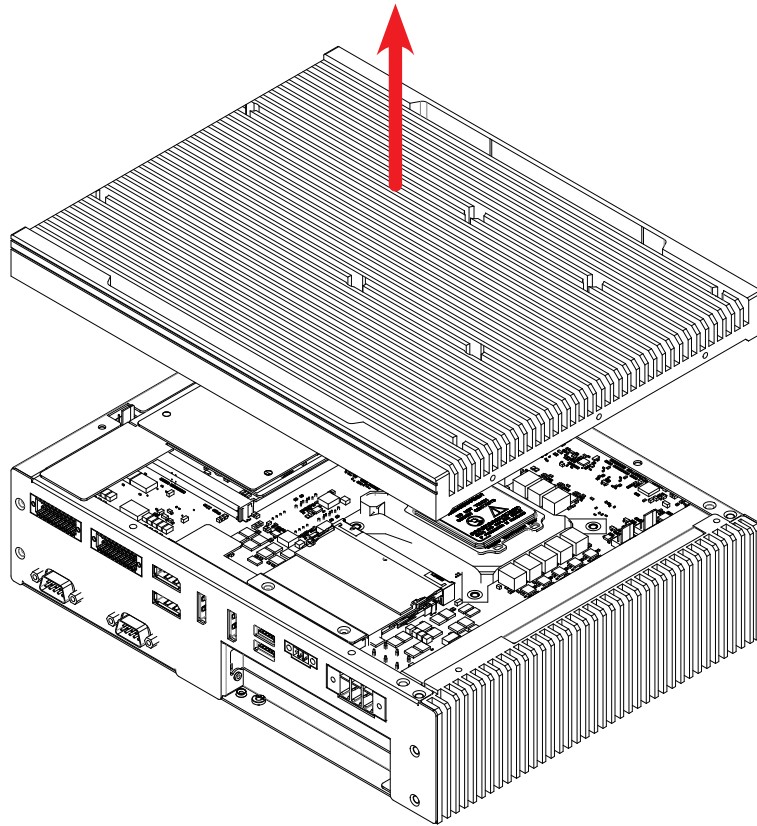

EVS-3000F

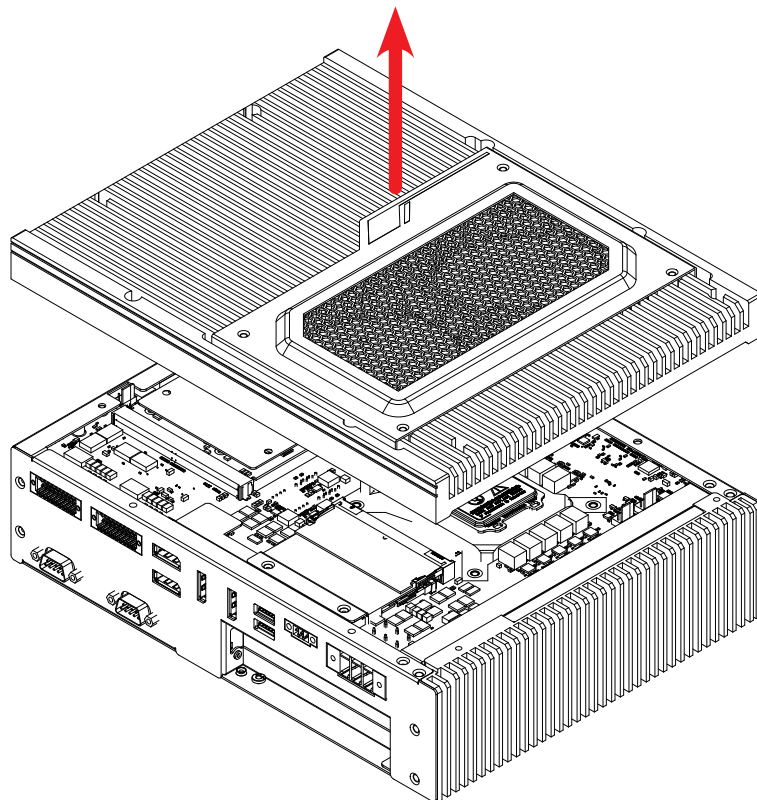

Step 3 Check the CPU position.

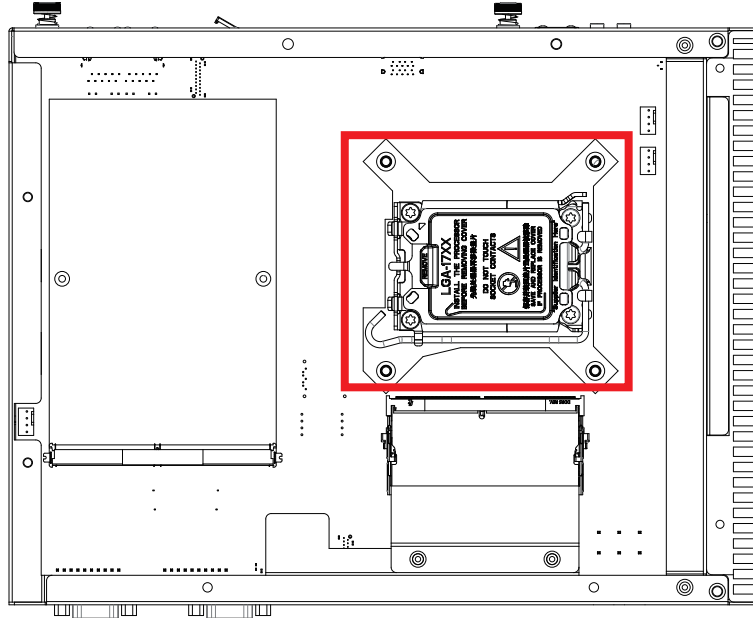

Step 4 open the CPU slot. (Be careful with the CPU pins)

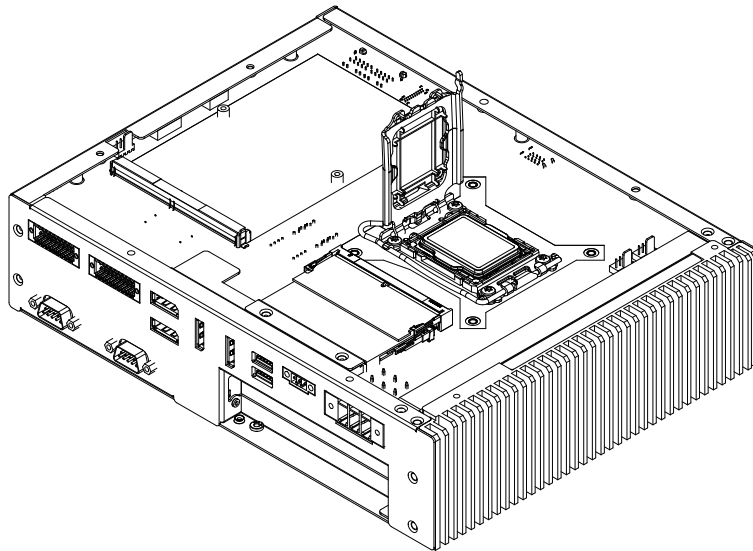

Step 5 Install the CPU.(Align the notches carefully)

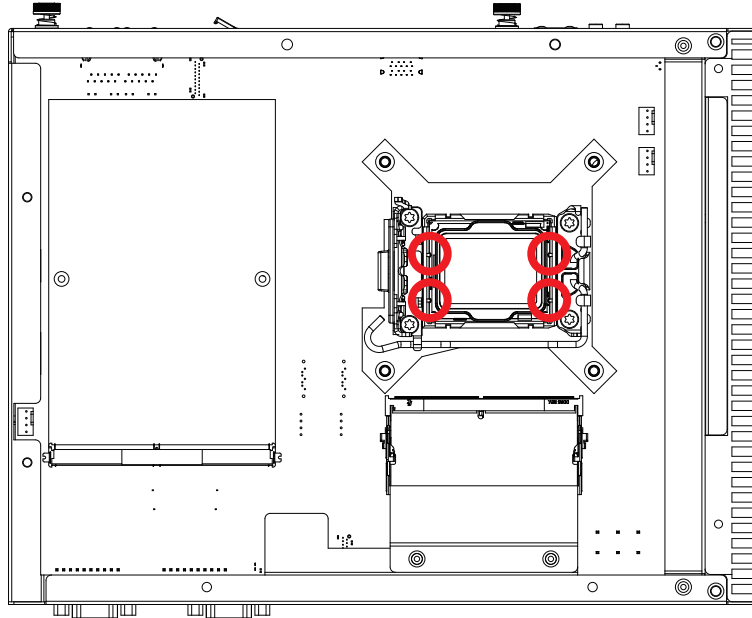

Step 6 Close the cover.

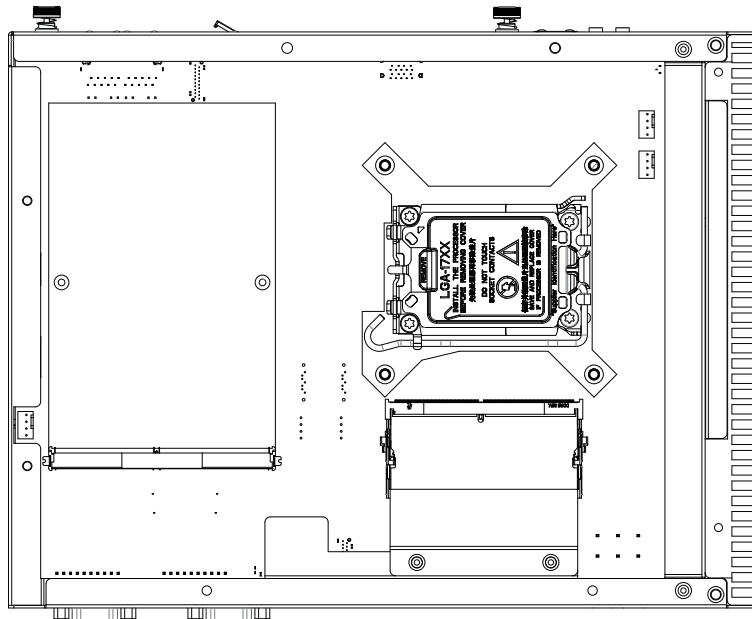

Step 7 Remove the top cover and apply thermal paste like “X”.

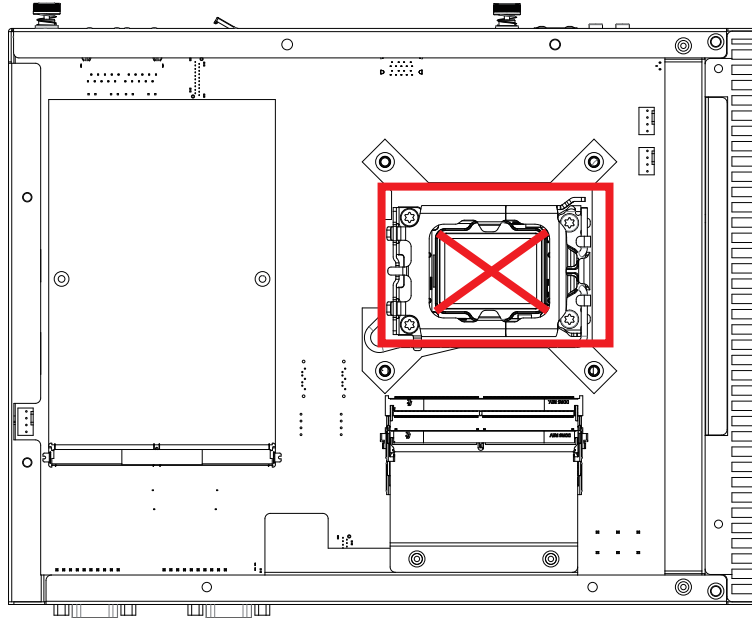

3.3 Installing DDR5 SO-DIMM Modules

Step 1 Remove TWO F-M3x5L screws and Remove the copper plate.

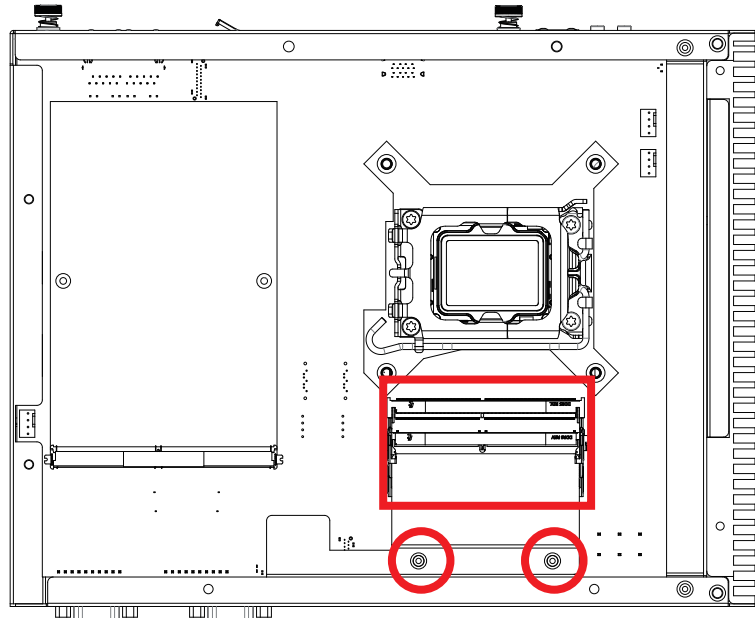

Step 2 Make sure the RAM module is locked by the memory slot.

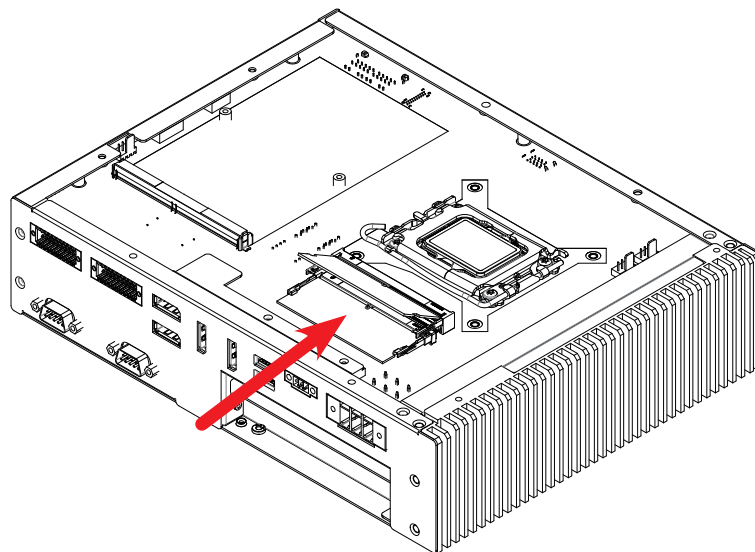

Step 3 Install the copper plate and secure it with two F-M3x5L screws.

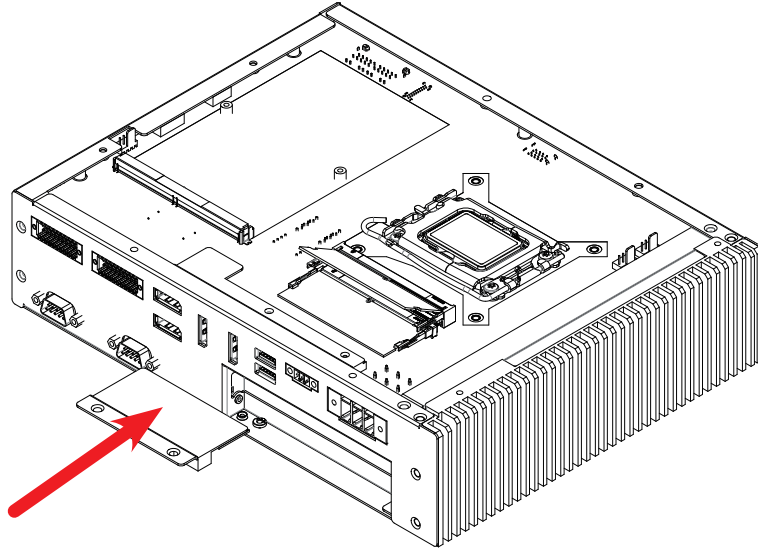

Step 4 Finish.

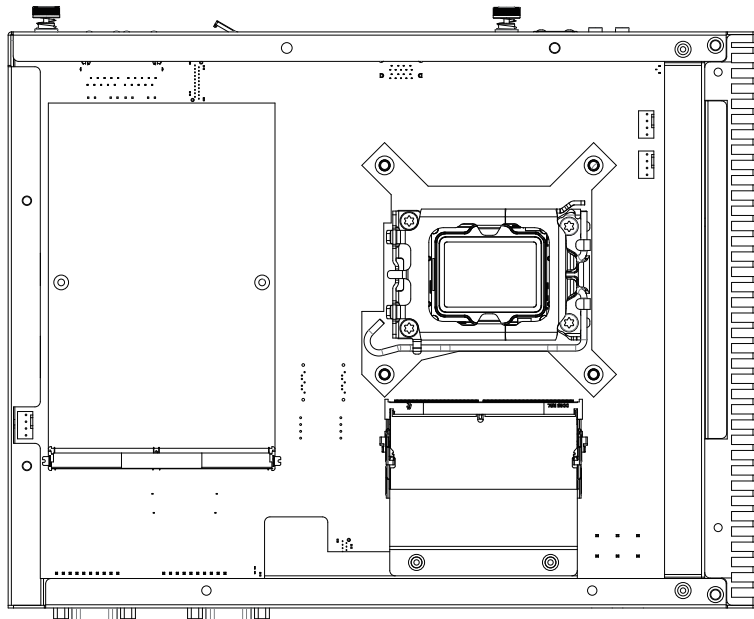

3.4 Installing M.2 (Key B/E/M)

Check the positions of **Key B 2280**, **Key E 2230**, and **Key M 2280**.

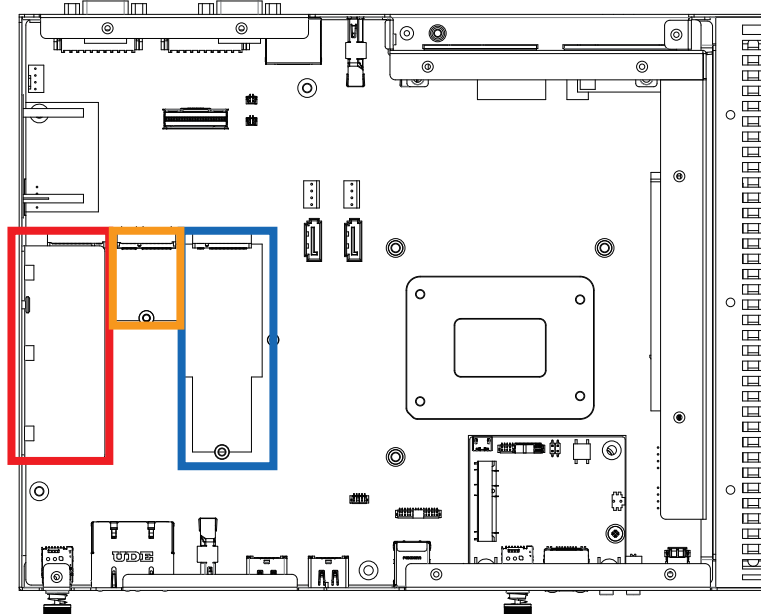

3.4.1 M.2- KEY.M 2280

Step 1 Remove the three M3 screws and take out Key M 2280, along with the thermal copper plate.

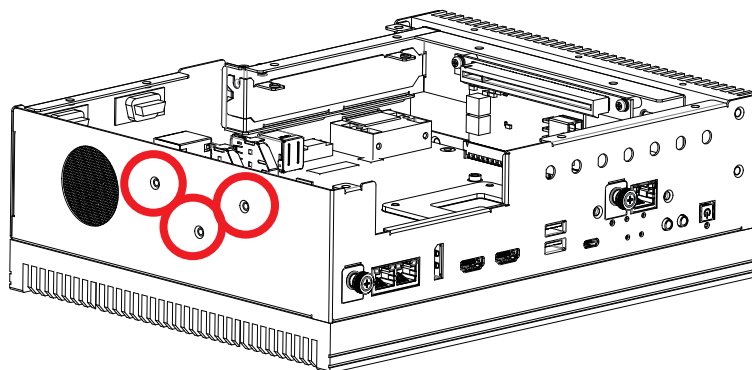

Step 2 Install M.2 card into the M.2 slot.

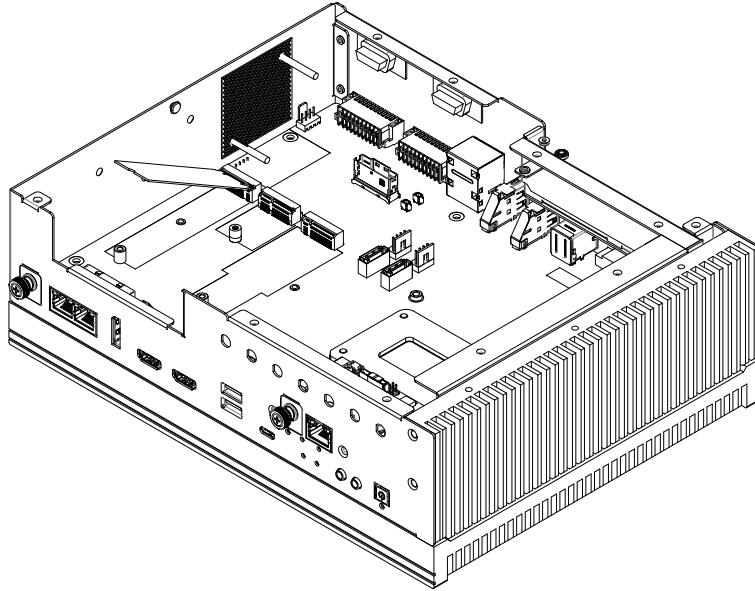

Step 3 Fasten one PH-M3x4L screw.

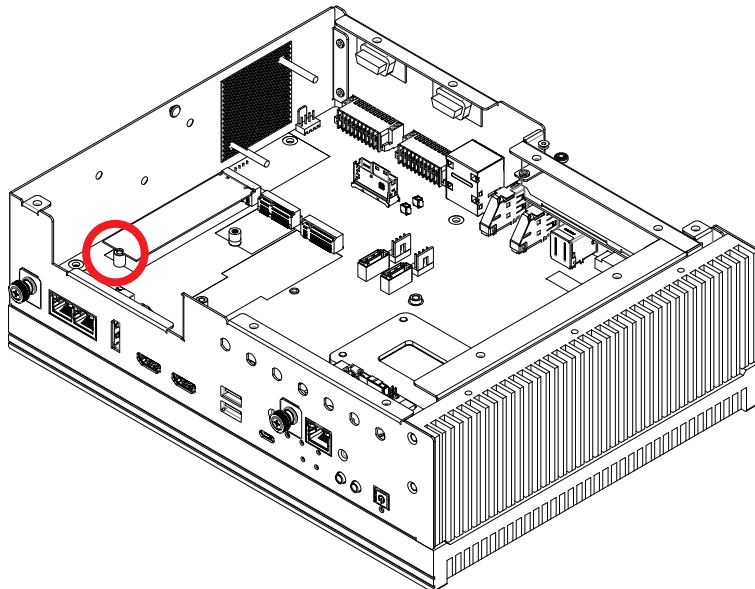

Step 4 Install the thermal copper plate.

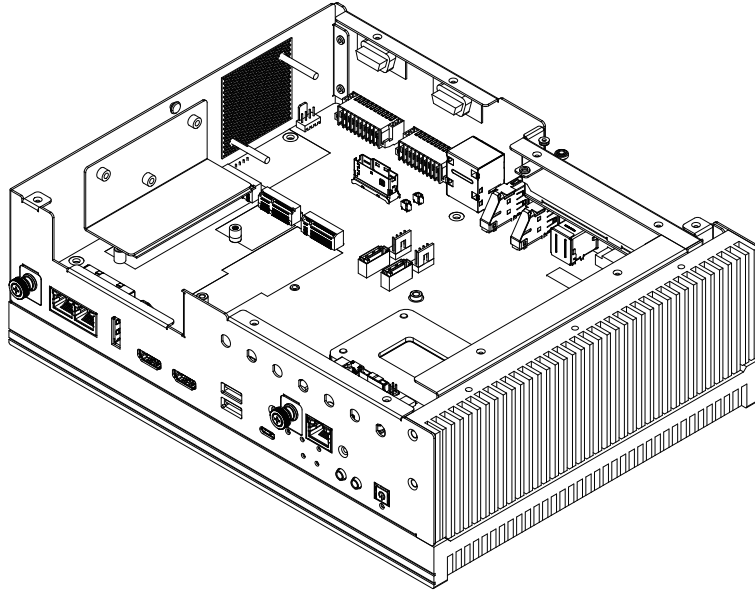

3.4.2 KEY B 2280

Step 1 Install KEY B 2280.

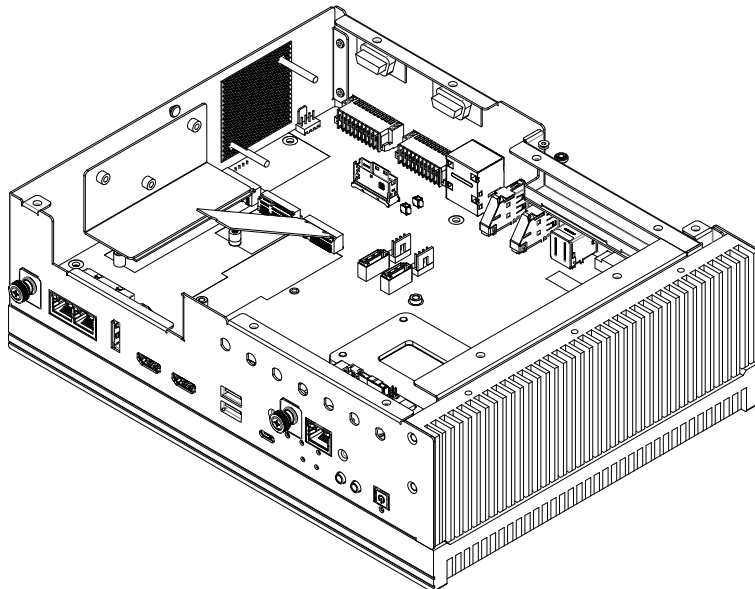

Step 2 Fasten one PH-M3x4L screw.

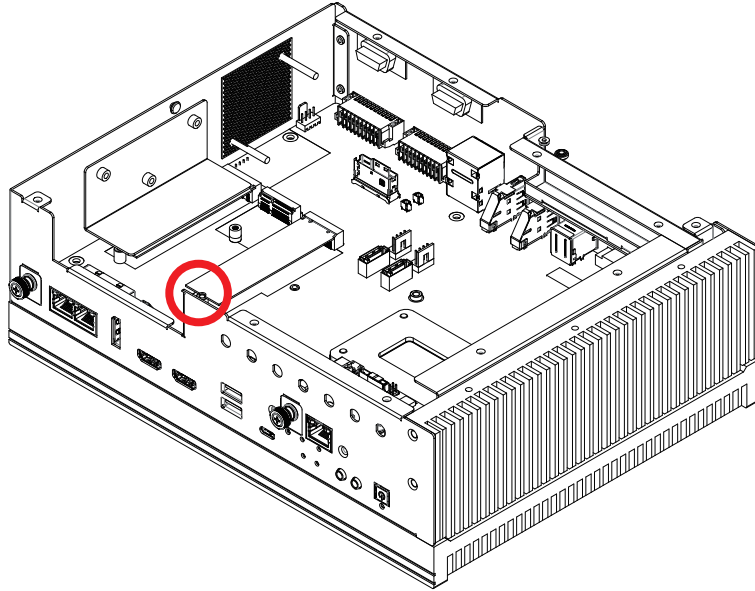

3.4.3 KEY B 3052

Step 1 Check that 62-03P0997-30A is in the accessory box.

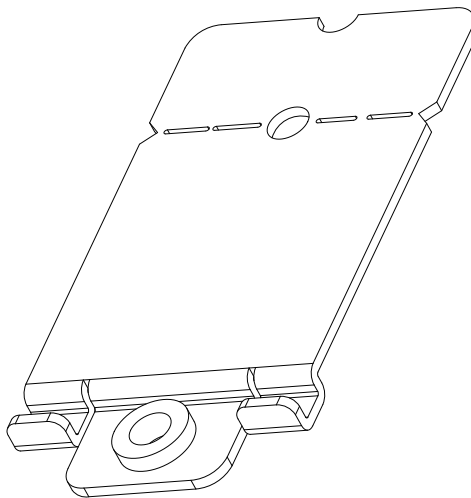

Step 2 Remove the metal plate above 62-03P0997-30A

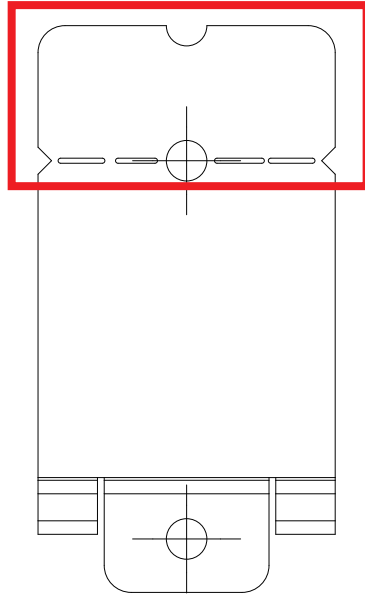

Step 3 Fasten 62-03P0997-30A with one PH-M3x4L screw.

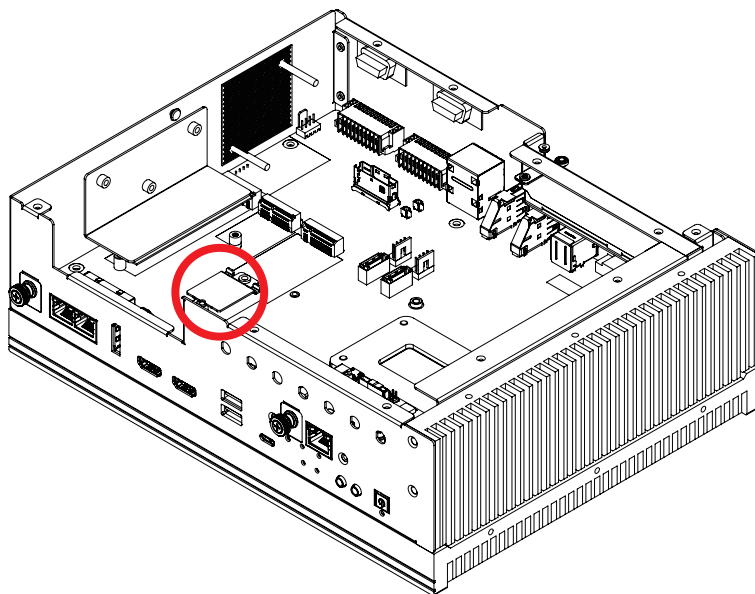

Step 4 Install KEY B 3052

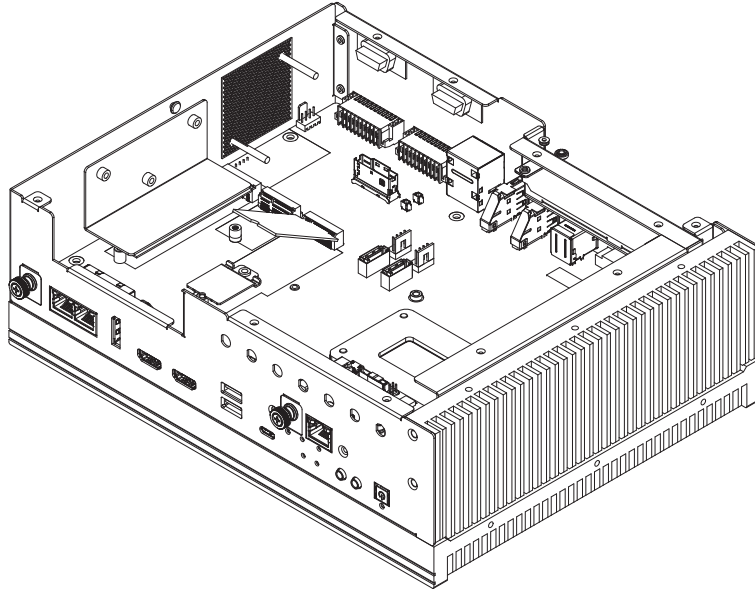

Step 5 Fasten one PH-M3x4L screw.

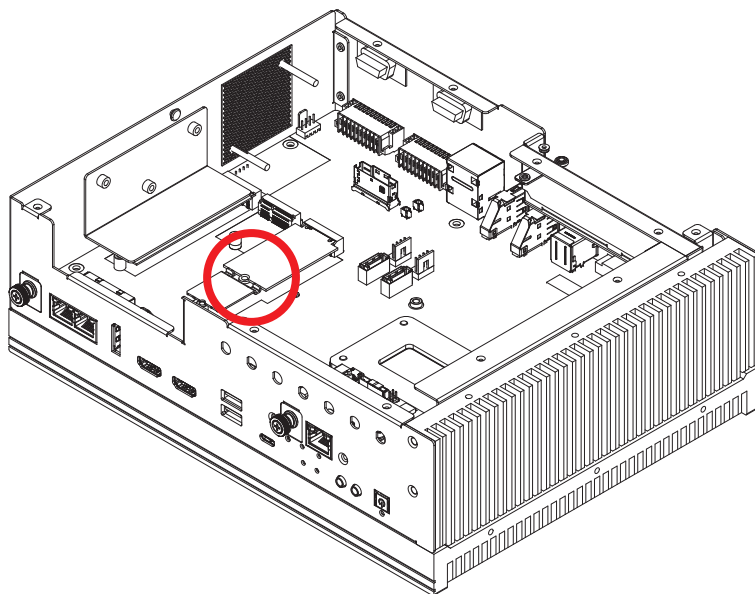

3.4.4 Key E 2230

Step 1 Install Key E 2230.

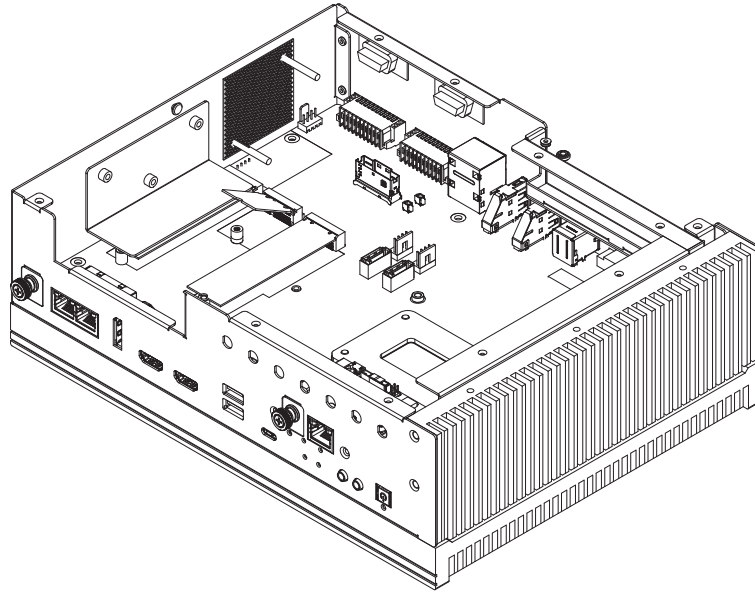

Step 2 Fasten one PH-M3x4L screw.

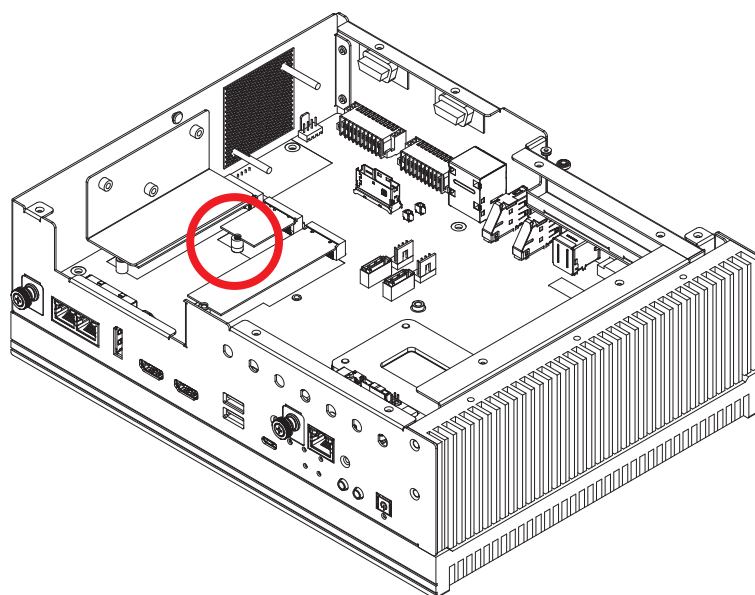

3.5.2 EVS-3300&EVS-3400 install front access M.2

Step 1 Check the position of the M.2 front panel slot.

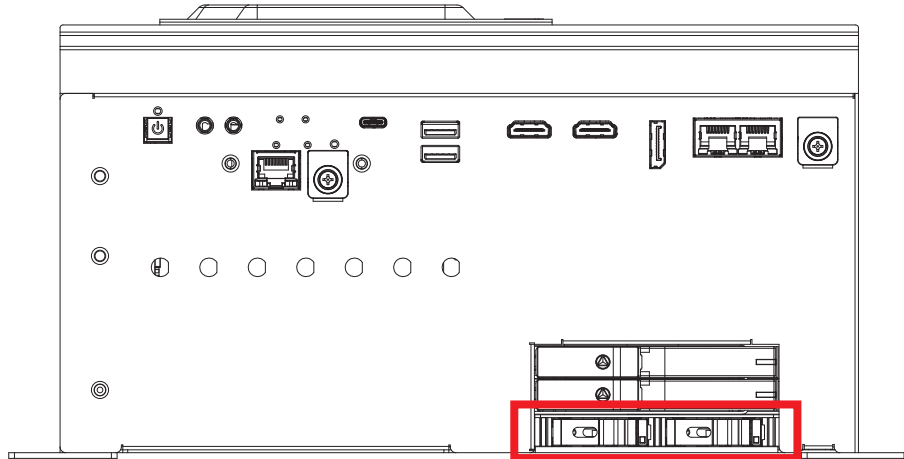

Step 2 Open and remove the M.2 tray.

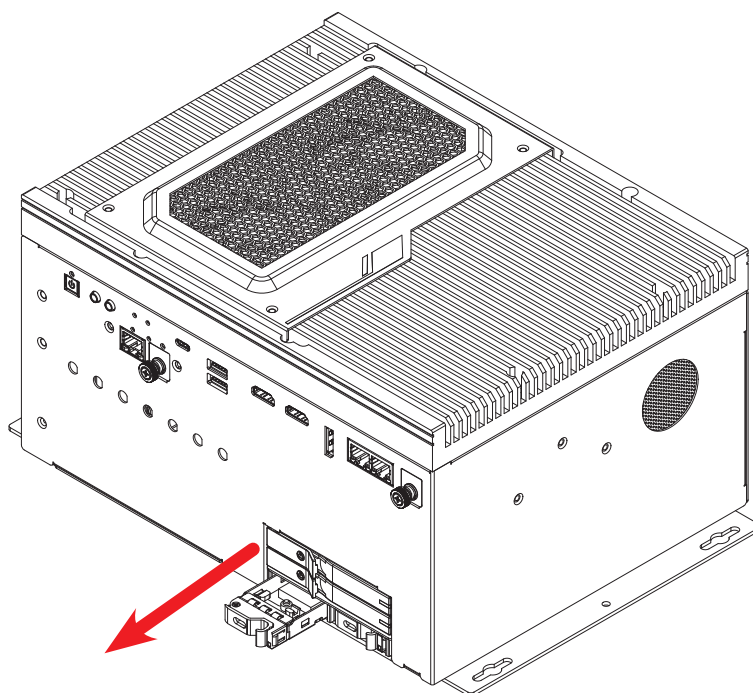

Step 3 Press the side switches to remove the aluminum plate.

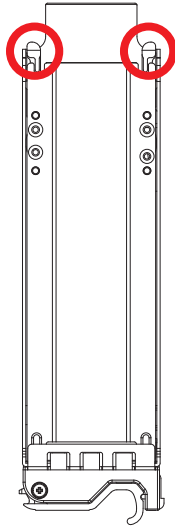

Step 4 Install the M.2.

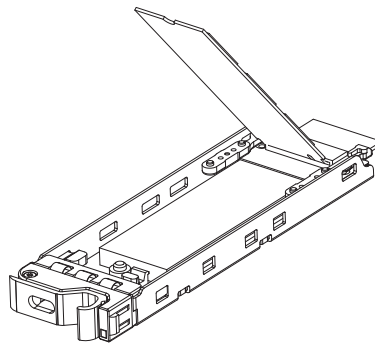

Step 5 Replace the aluminum plate and insert the tray back into the slot.

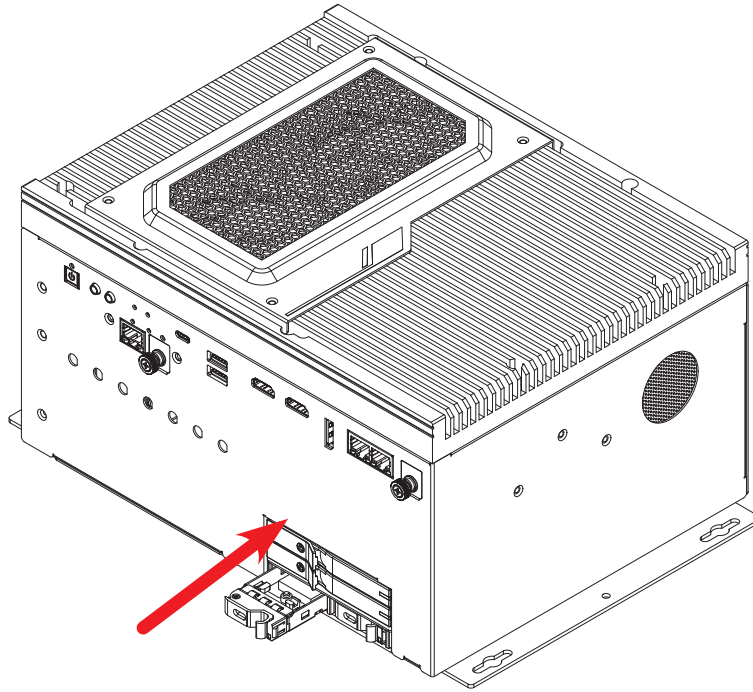

3.6 PCIe Card

Step 1 Check the PCIe slot position.

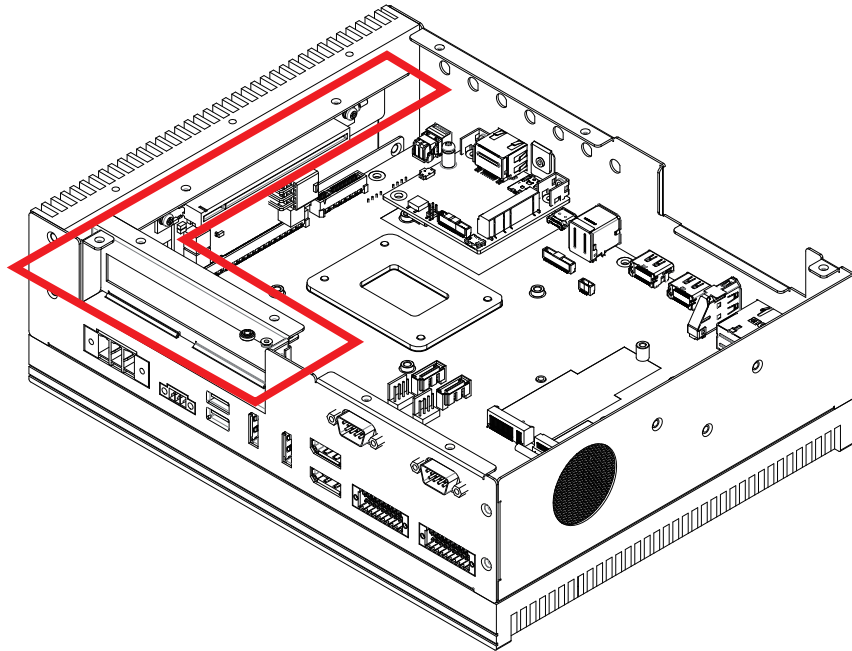

Step 2 Remove the riser card module.

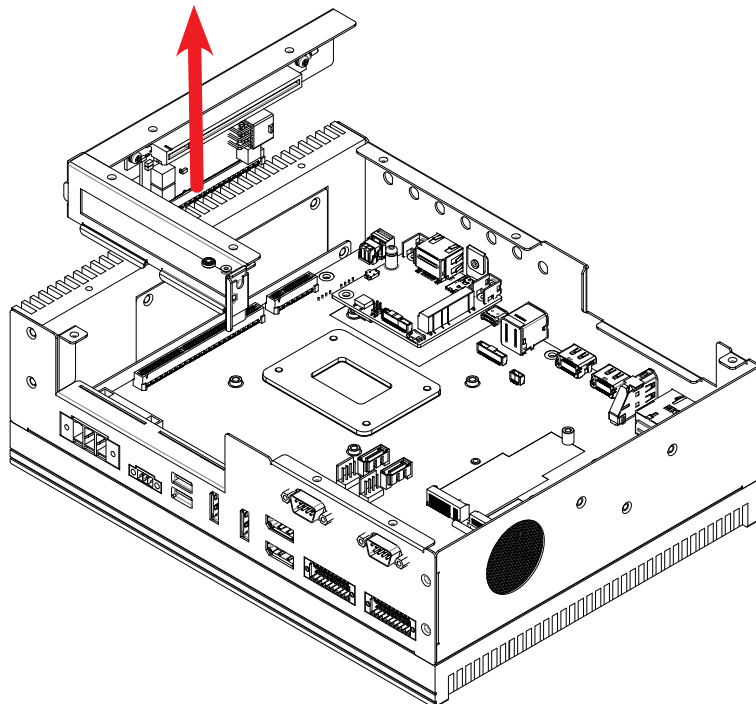

Step 3 Install the PCIe card.

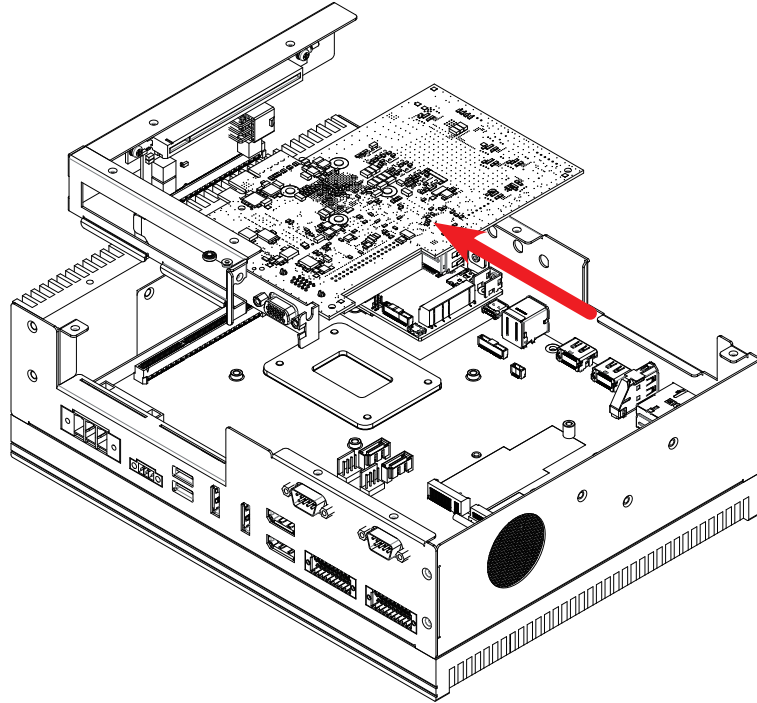

Step 4 Install the riser card module.

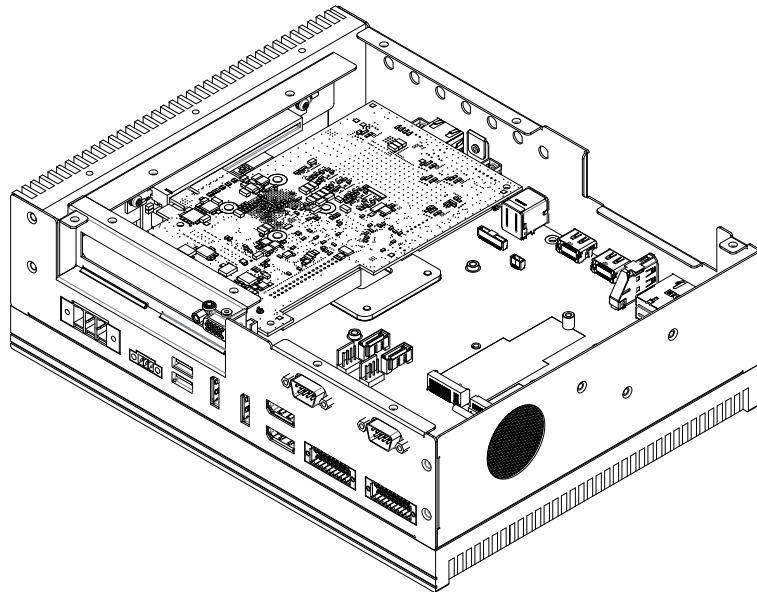

3.7 SIM Card

Step 1 Check the SIM card slot.

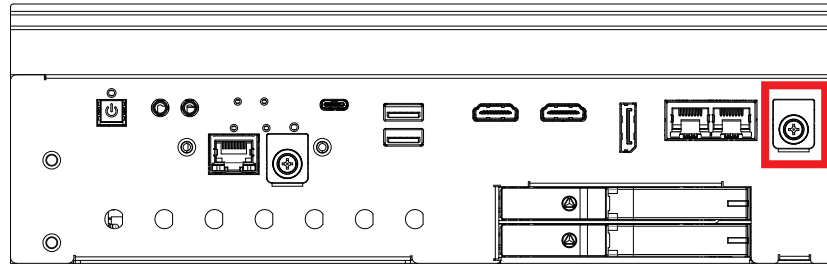

Step 2 Inserting SIM Card, make sure the system power is not plugged.

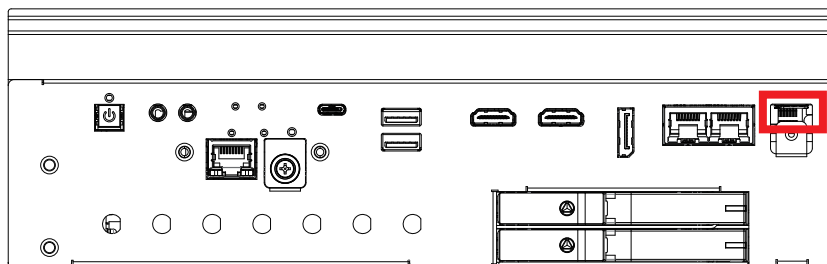

3.8 Installing Antenna Cable

Step 1 Check the antenna position.

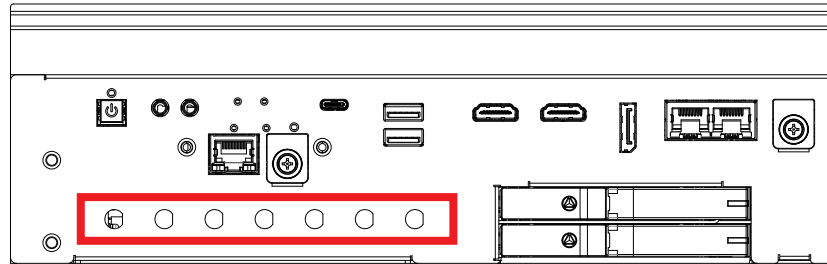

Step 2 Check antenna parts (cable and washers).



3.9 Mounting Your EVS-3000

3.9.1 Wall Mount Bracket for EVS-3000 with SIX M3x6L screws.

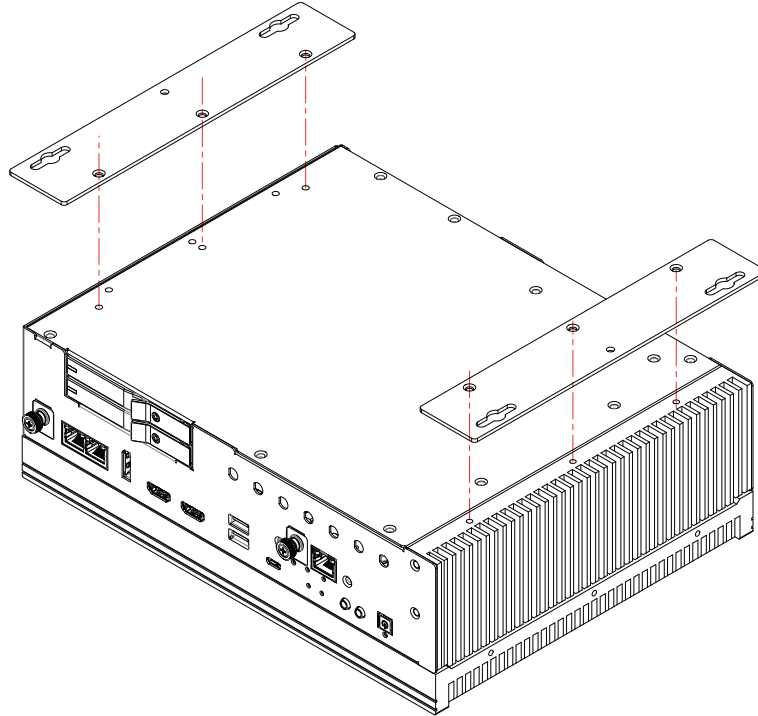

3.9.2 Wall Mount Bracket for EVS-3000F with SIX M3x6L screws.

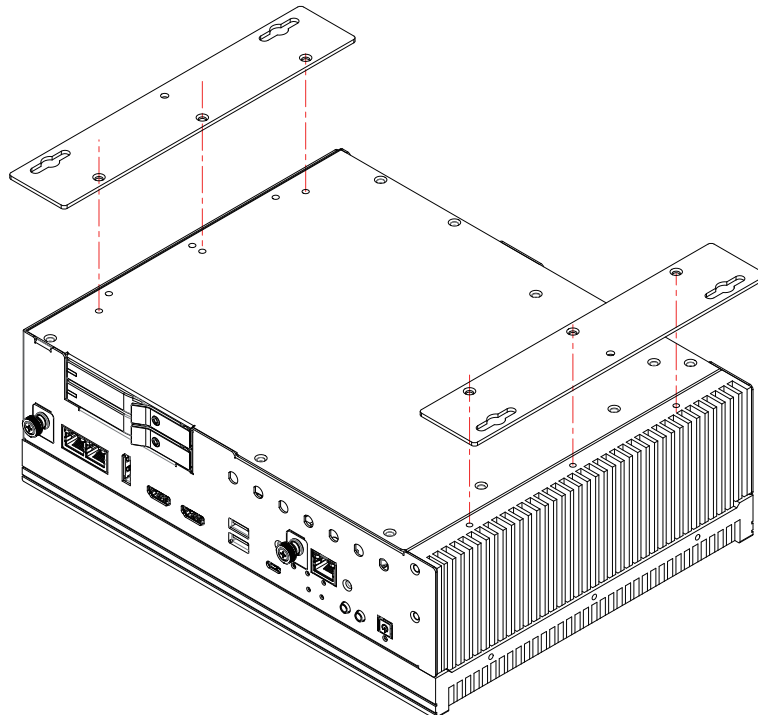

3.9.3 Install VESA Mount and fasten six I-M3x6L screws.

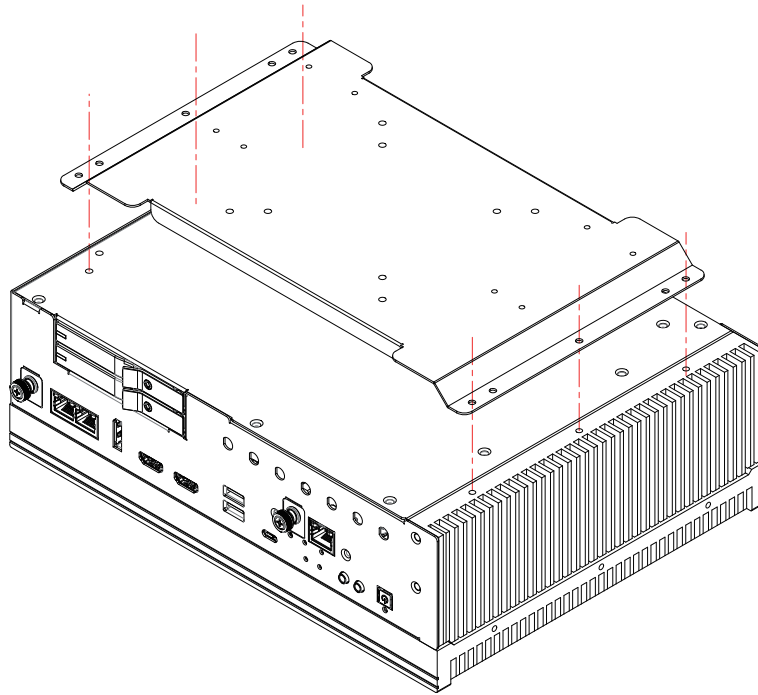

3.9.4 Install Din Rail with VESA Mount Kit and fasten six I-M3x6L screws.

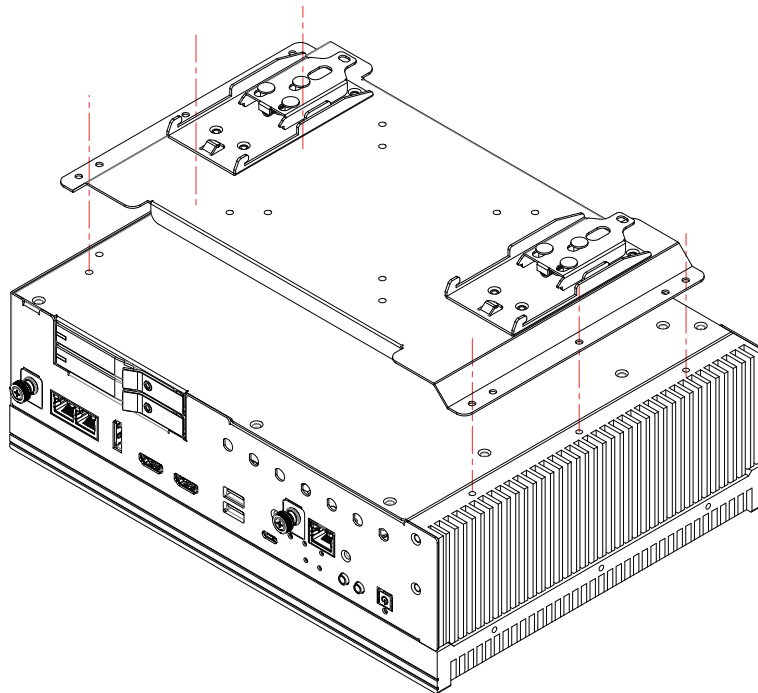

4

BIOS SETUP

4.1 BIOS Settings

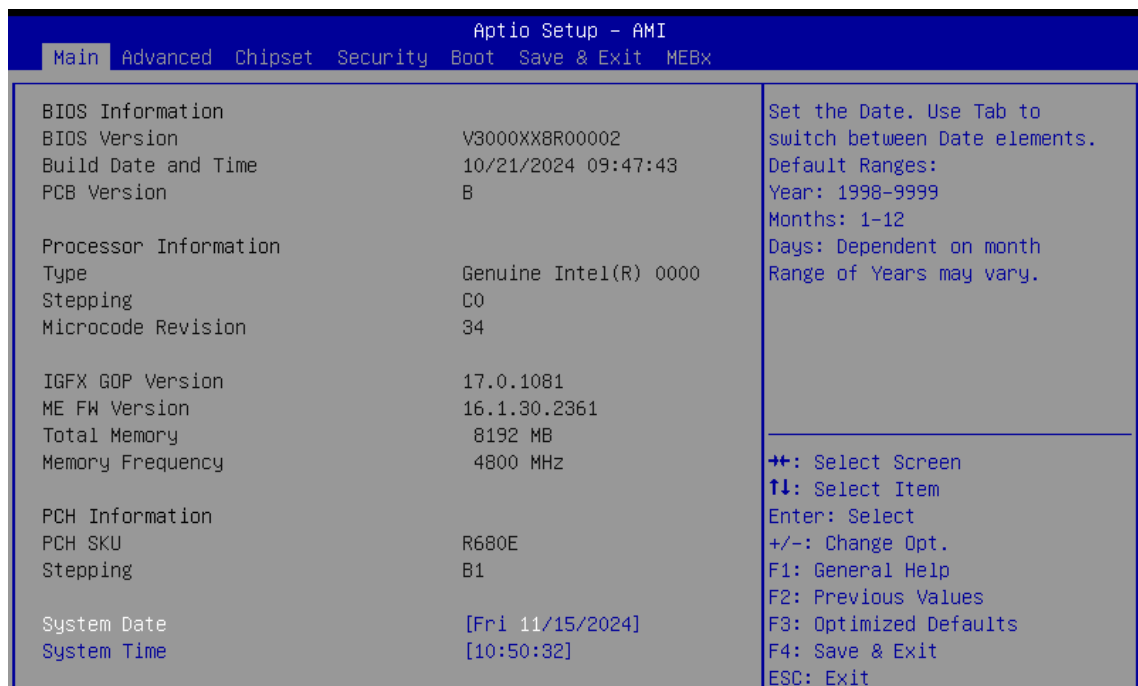

Figure 4-1 : Entering Setup Screen

BIOS provides an interface for users to check and change system configuration. The BIOS setup program is accessed by pressing the key when POST display output is shown.

4.2 Main

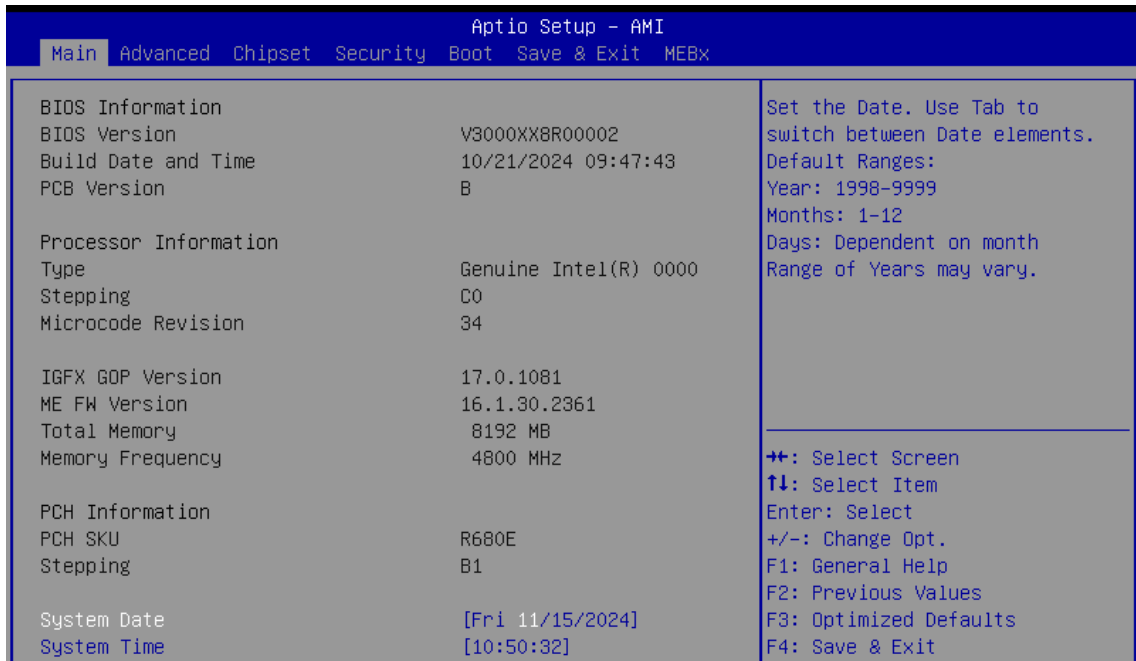

Figure 4-2 : BIOS Main Menu

The main menu displays BIOS version and system information. There are two options on Main menu.

System Date

Set the Date. Use Tab to switch between Date elements.

Default Ranges:

Year: 1998-9999

Months: 1-12

Days: Dependent on month Range of Years may vary.

System Time

Set the Time. Use Tab to switch between Time elements.

4.3 Advanced

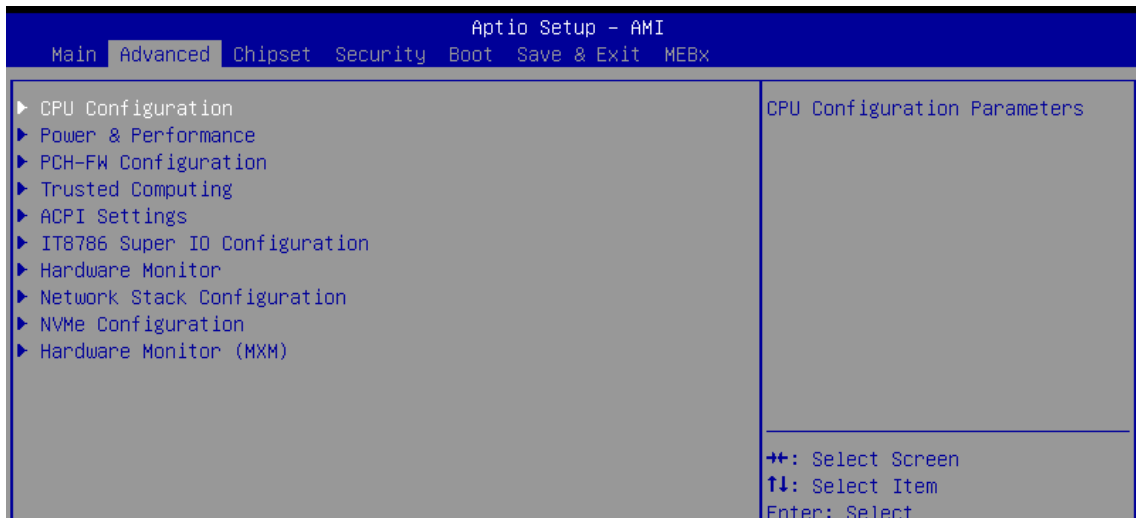

Figure 4-3 : BIOS Advanced Menu

Select advanced tab to enter advanced BIOS setup options such as CPU configuration, ACPI settings, and Super IO configuration.

4.3.1 CPU Configuration

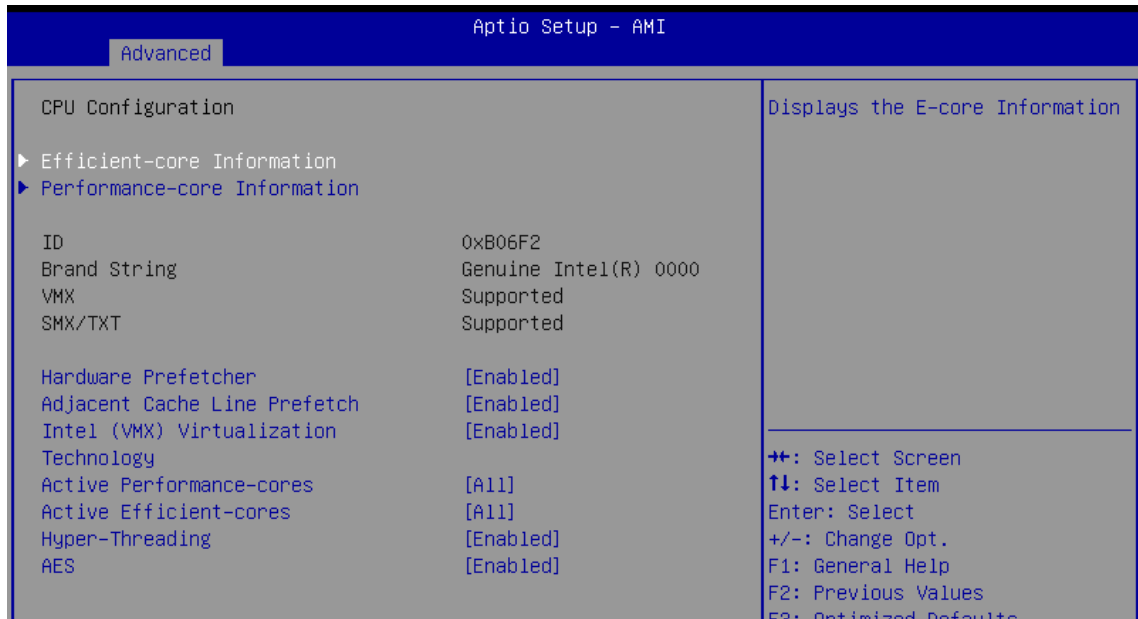

Figure 4-3-1 : CPU Configuration

Hardware Prefetcher

To turn on/off the MLC streamer prefetcher.

Adjacent Cache Line Prefetch

To turn on/off prefetching of adjacent cache lines.

Intel (VMX) Virtualization Technology

When enabled, a VMM can utilize the additional hardware capabilities provided by Vanderpool Technology.

Active Processor Cores

Number of P-cores to enable in each processor package. Note: Number of Cores and E-cores are looked at together. When both are {0,0}, Pcode will enable all cores.

Active Efficient-cores

Number of E-cores to enable in each processor package. Note: Number of Cores and E-cores are looked at together. When both are {0,0}, Pcode will enable all cores.

Hyper-Threading

Enable or Disable Hyper-Threading Technology.

AES

Enable/Disable AES (Advanced Encryption Standard)

4.3.2 CPU - Power Management Control

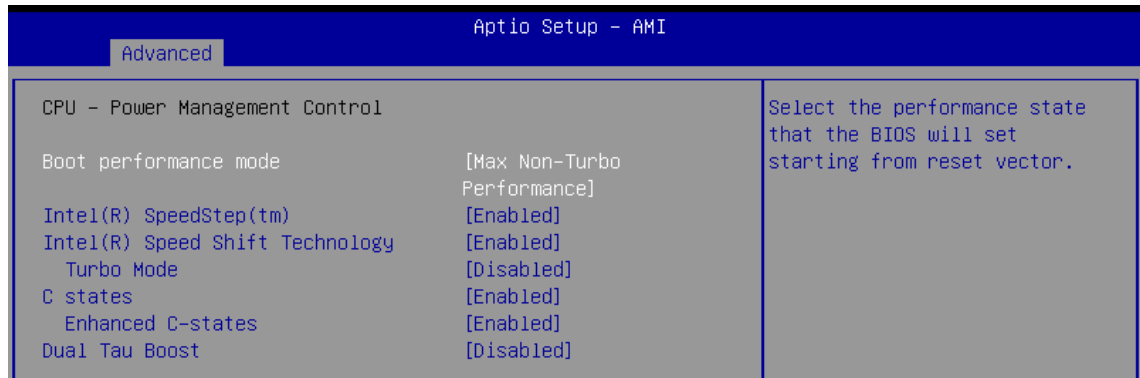

Figure 4-3-2 : CPU - Power Management Control

Boot performance mode

Select the performance state that the BIOS will set starting from reset vector.

Intel (R) SpeedStep (tm)

Allows more than two frequency ranges to be supported.

Intel (R) Speed shift Technology

Enable/Disable Intel® Speed Shift Technology support. Enabling will expose the CPPCv2 interface to allow for hardware controlled P-states.

Turbo Mode

Enable/Disable processor Turbo Mode (requires EMTTM enabled too). AUTO means enabled.

C states

Enable/Disable CPU Power Management. Allows CPU to go to C states when it's not 100% utilized.

Enhanced C-states

Enable/Disable C1E. When enabled, CPU will switch to minimum speed when all cores enter C-State.

Dual Tau Boost

Enable Dual Tau Boost feature. This is only applicable for Desktop 35W/65W/125W sku. When DPTF is enabled this feature is ignored.

4.3.3 PCH-FW Configuration

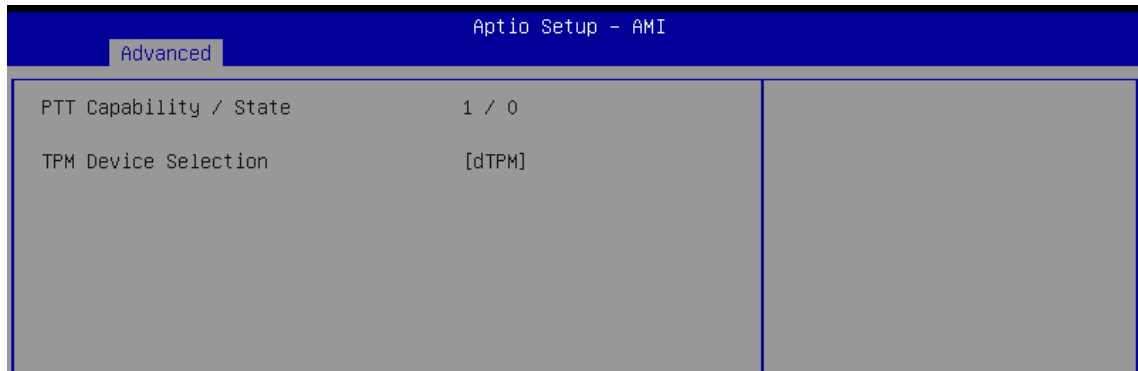

Figure 4-3-3 : PCH-FW Settings

TPM Device Selection

Selects TPM device: PTT or discrete TPM. PTT - enables PTT in SkuMgr dTPM 1.2 - disables PTT is SkuMgr Warning! PTT/dTPM will be disabled and all data saved on it will be lost.

4.3.4 Trusted Computing

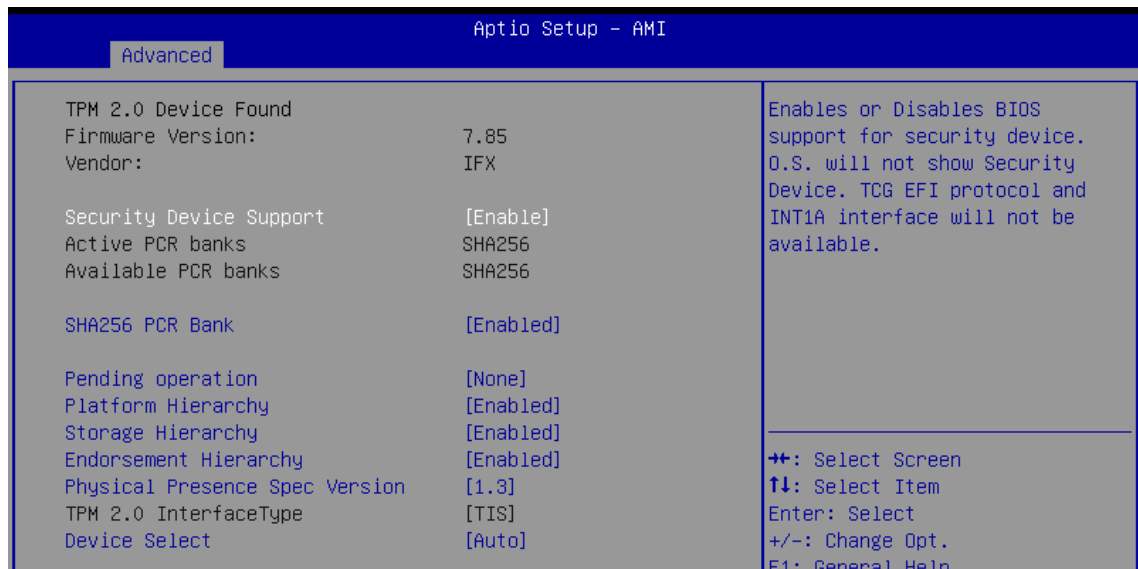

Figure 4-3-4 : Trusted Computing

Control the TPM device status and display related information if TPM chip is present.

4.3.5 ACPI Settings

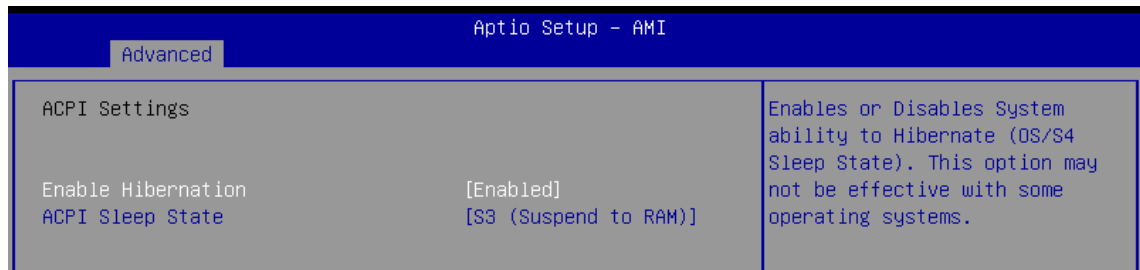

Figure 4-3-5 : ACPI Settings

Enable Hibernation

Enables or Disables System ability to Hibernate (OS/S4 Sleep State). This option may not be effective with some operating systems.

ACPI Sleep State

Select the highest ACPI sleep state the system will enter when the SUSPEND button is pressed.

4.3.6 Serial Port (X) Configuration

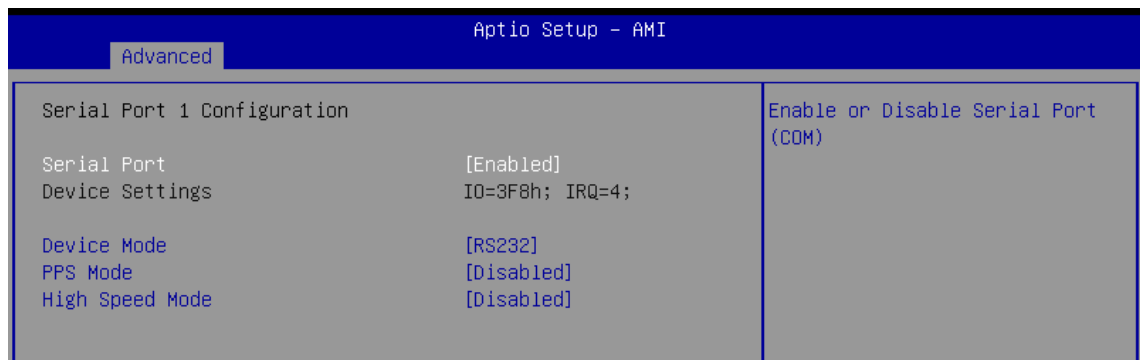

Figure 4-3-6 : Serial Port Configuration

Serial Port

Enable or Disable Serial Port (COM)

Device Mode

Select Device Mode.

PPS Mode

Enable or Disable PPS.

High Speed Mode (Only Serial Port 1)

Enable or Disable Serial Port High Speed.

4.3.7 Hardware Monitor

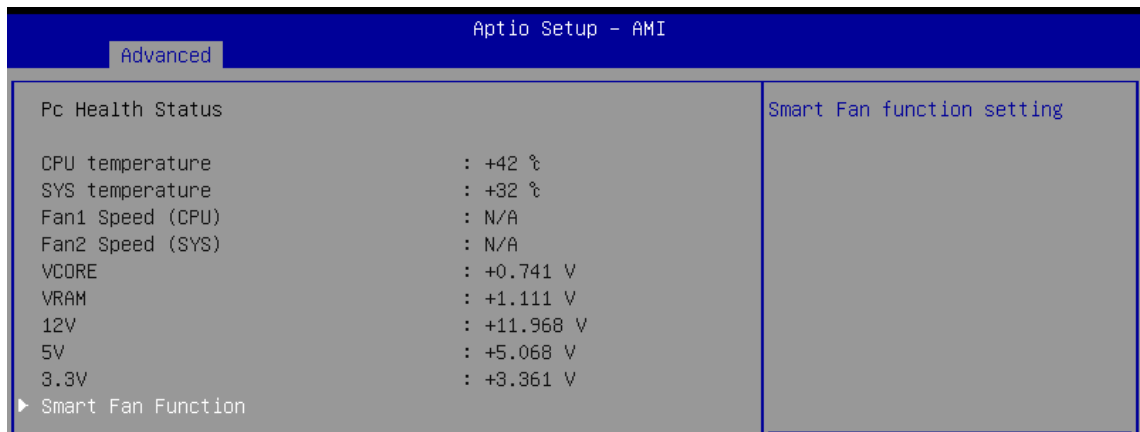
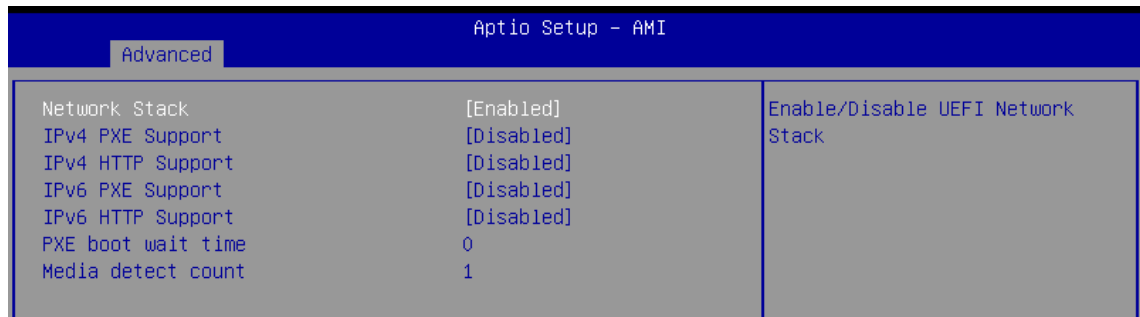

Figure 4-3-7 : Hardware Monitor

Smart Fan Function

Smart Fan function setting.

4.3.8 Network Stack Configuration



The screenshot shows the 'Advanced' tab of the 'Aptio Setup - AMI' BIOS. The 'Network Stack' is set to '[Enabled]'. Other settings include: IPv4 PXE Support [Disabled], IPv4 HTTP Support [Disabled], IPv6 PXE Support [Disabled], IPv6 HTTP Support [Disabled], PXE boot wait time 0, and Media detect count 1. A button labeled 'Enable/Disable UEFI Network Stack' is visible on the right side of the configuration area.

Setting	Value	Action
Network Stack	[Enabled]	Enable/Disable UEFI Network Stack
IPv4 PXE Support	[Disabled]	
IPv4 HTTP Support	[Disabled]	
IPv6 PXE Support	[Disabled]	
IPv6 HTTP Support	[Disabled]	
PXE boot wait time	0	
Media detect count	1	

Figure 4-3-8 : Network Stack Configuration

Network Stack

Enable/Disable UEFI Network Stack.

IPv4 PXE Support

Enable/Disable IPv4 PXE boot support. If disabled, IPv4 PXE boot support will not be available.

IPv4 HTTP Support

Enable/Disable IPv4 HTTP boot support. If disabled, IPv4 HTTP boot support will not be available.

IPv6 PXE Support

Enable/Disable IPv6 PXE boot support. If disabled, IPv6 PXE boot support will not be available.

IPv6 HTTP Support

Enable/Disable IPv6 HTTP boot support. If disabled, IPv6 HTTP boot support will not be available.

PXE boot wait time

Wait time in seconds to press ESC key to abort the PXE boot. Use either +/- or numeric keys to set the value.

Media detect count

Number of times the presence of media will be checked. Use either +/- or numeric keys to set the value.

4.3.9 NVMe Configuration

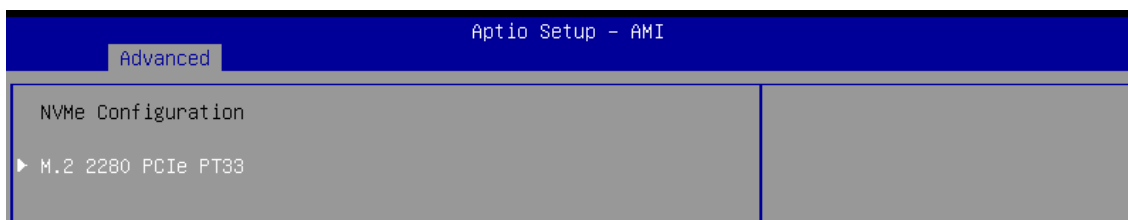

Figure 4-3-9 : NVMe Configuration

Display NVMe controller and Drive information.

4.3.10 Hardware Monitor (MXM)

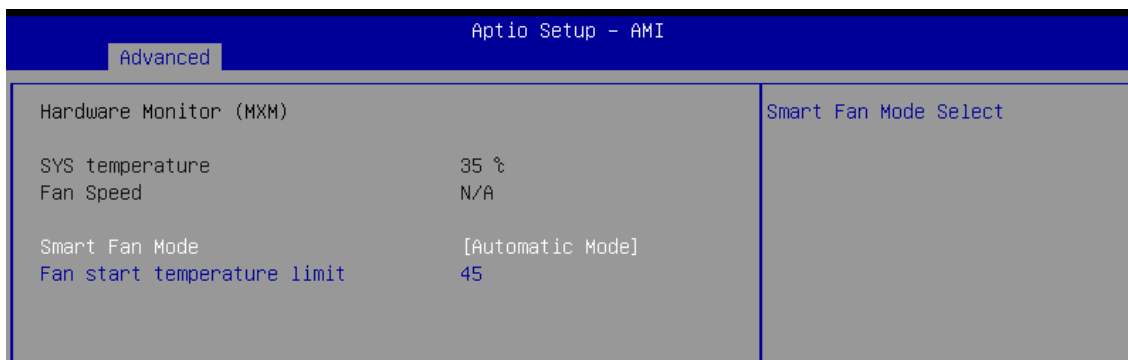

Figure 4-3-10 : Hardware Monitor (MXM)

Smart Fan Mode

Smart Fan Mode Select

Fan start temperature limit

Fan will work when temperature higher than this limit. Rang 0~124.

Manual Duty Cycle Setting

Fan will work with this Manual Duty Cycle Value. Rang 0~255.

4.4 Chipset Menu

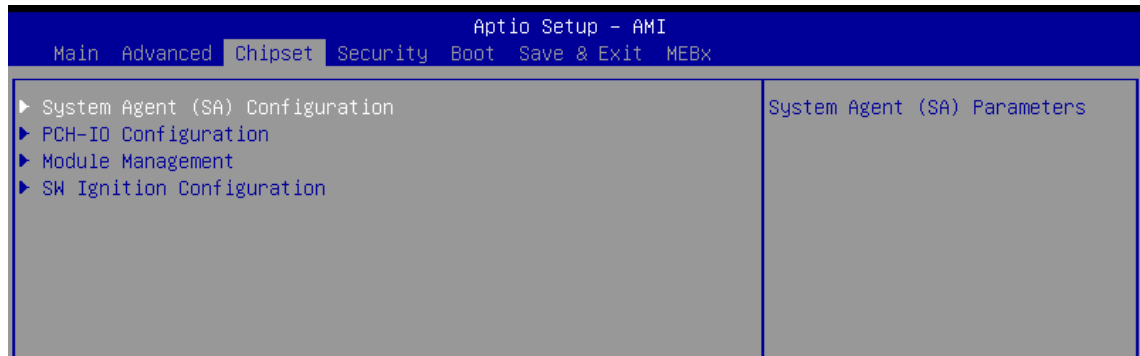

Figure 4-4 : BIOS Chipset Menu

4.4.1 System Agent (SA) Configuration

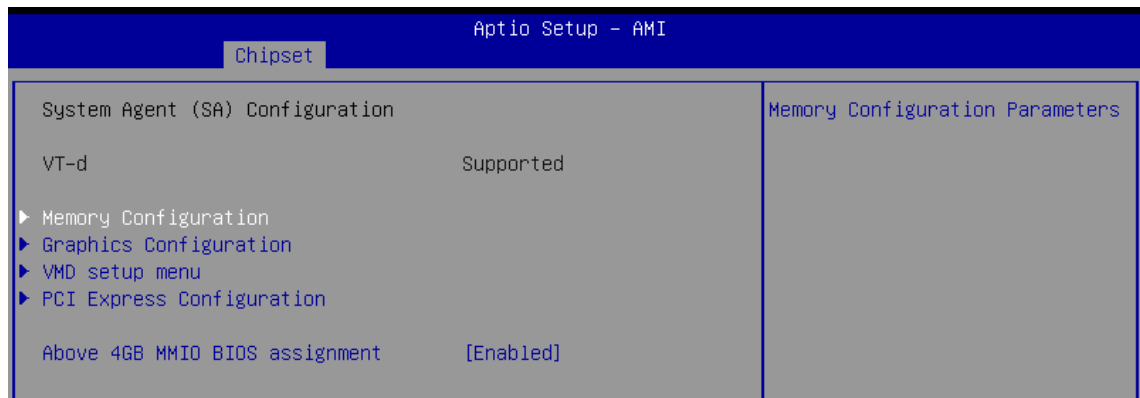

Figure 4-4-1 : System Agent (SA) Configuration

Above 4GB MMIO BIOS assignment

Enable/Disable above 4GB MemoryMappedIO BIOS assignment

This is enabled automatically when Aperture Size is set to 2048MB.

4.4.2 Memory Configuration

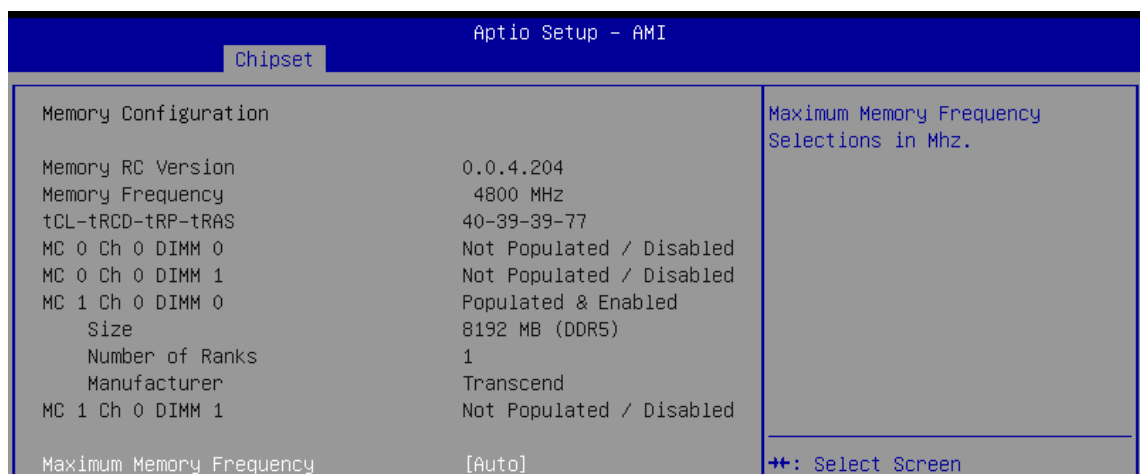
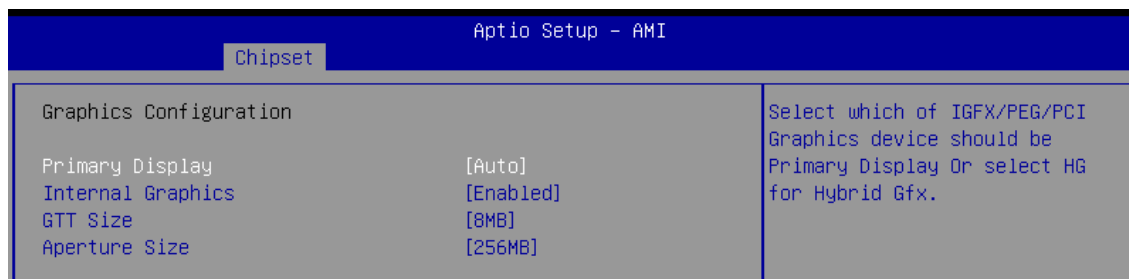

Figure 4-4-2 : Memory Information

Maximum Memory Frequency

Maximum Memory Frequency Selections in Mhz.

4.4.3 Graphics Configuration



The screenshot shows the 'Aptio Setup - AMI' interface with the 'Chipset' tab selected. The 'Graphics Configuration' section is highlighted, showing settings for Primary Display, Internal Graphics, GTT Size, and Aperture Size. A help text box on the right explains the Primary Display selection options.

Aptio Setup - AMI	
Chipset	
Graphics Configuration	Select which of IGFX/PEG/PCI Graphics device should be Primary Display Or select HG for Hybrid Gfx.
Primary Display	[Auto]
Internal Graphics	[Enabled]
GTT Size	[8MB]
Aperture Size	[256MB]

Figure 4-4-3 : Graphics Configuration

Primary Display

Select which of IGFX/PEG/PCI Graphics device should be Primary Display Or select HG for Hybrid Gfx.

Internal Graphics

Keep IGFX enabled based on the setup options.

GTT Size

Select the GTT Size

Aperture Size

Select the Aperture Size

Note : Above 4GB MMIO BIOS assignment is automatically enabled when selecting > 2048MB aperture. To use this feature, please disable CSM Support.

4.4.4 VMD Configuration



The screenshot shows the 'Aptio Setup - AMI' interface with the 'Chipset' tab selected. The 'VMD Configuration' section is highlighted, showing the 'Enable VMD controller' setting set to [Disabled]. A help text box on the right explains the VMD controller options.

Aptio Setup - AMI	
Chipset	
VMD Configuration	Enable/Disable to VMD controller
Enable VMD controller	[Disabled]

Figure 4-4-4 : VMD Configuration

Enable VMD controller

Enable/Disable to VMD controller

4.4.5 PCI Express Configuration (SA)

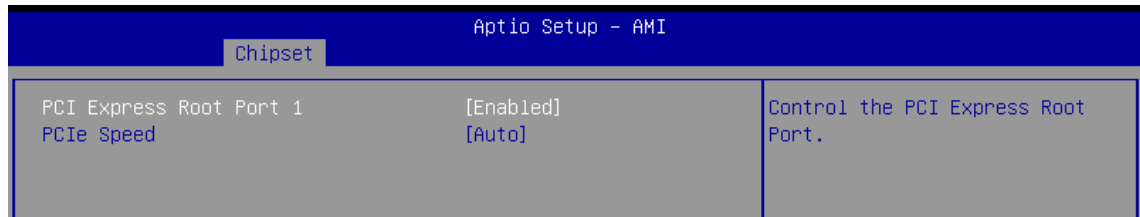

Figure 4-4-5 : PCI Express Configuration (SA)

PCI Express Root Port (X)

Control the PCI Express Root Port.

PCIe Speed

Configure PCIe Speed

4.4.6 PCH-IO Configuration

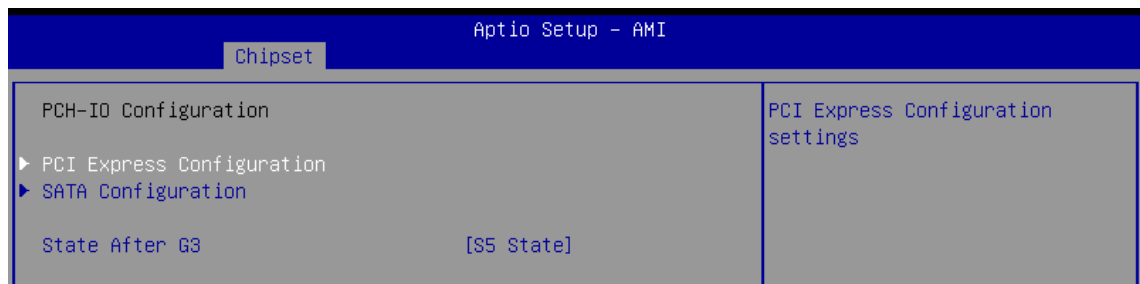

Figure 4-4-6 : PCH-IO Configuration

State After G3

Specify what state to go to when power is re-applied after a power failure (G3 state).

4.4.7 PCI Express Configuration (PCH)

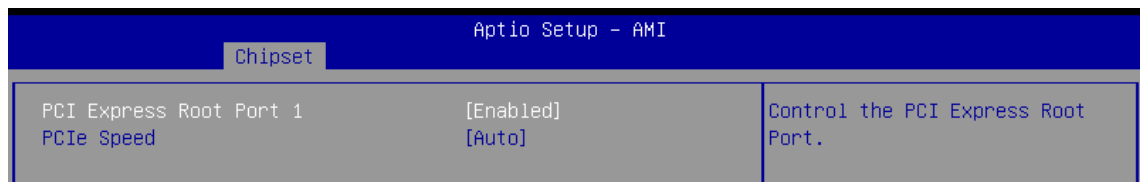

Figure 4-4-7 : PCI Express Configuration (PCH)

PCI Express Root Port (X)

Control the PCI Express Root Port.

PCIe Speed

Configure PCIe Speed.

4.4.8 SATA Configuration

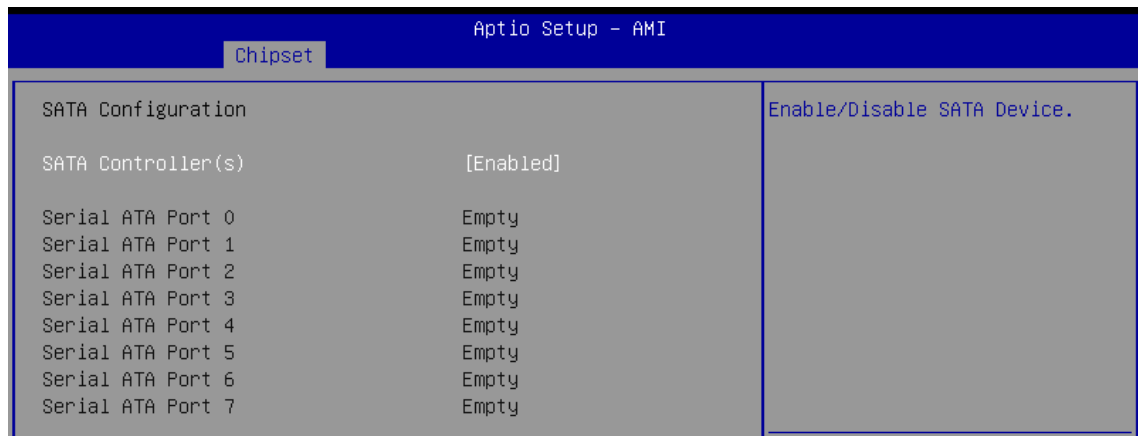

Figure 4-4-8 SATA Configuration

SATA Controller(s)

Enable/Disable SATA Device.

4.4.9 Module Management

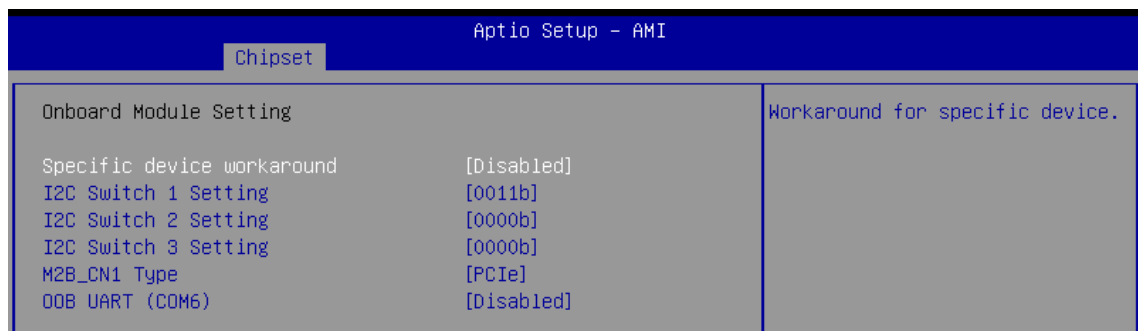

Figure 4-4-9 Module Management

Specific device workaround

Workaround for specific device.

Delay Time

0~255 (second).

I2C Switch (X) Setting

I2C Switch Setting. Bit 0~3 for Channel 0~3. 1 to enable, 0 to disable.

For example: 0101b for channel 0 & 2.

M2B_CN1 Type

Select M2B_CN1 Type.

OOB UART (COM6)

Enable/Disable OOB UART

Switch IC	Channel	Device
I2C Switch 1	0	Ignition
	1	Type C
	2	UPS
	3	No Device
I2C Switch 2	0	MXM
	1	M.2 Key E
	2	No Device
	3	No Device
I2C Switch 3	0	CPU PEG SLOT
	1	PCH PCIe SLOT 1
	2	PCH PCIe SLOT 2
	3	OOB

4.4.10 SW Ignition Configuration

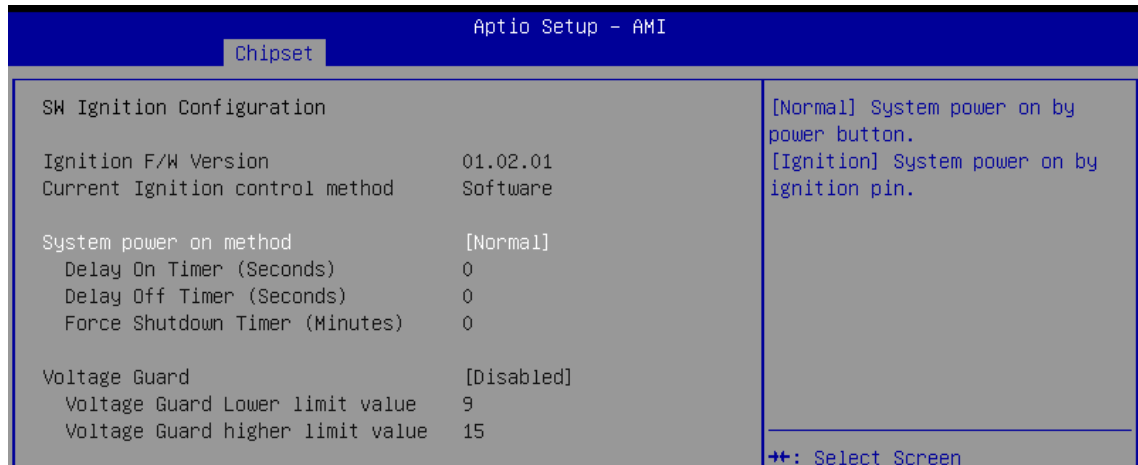

Figure 4-4-10 SW Ignition Configuration

System power on method

[Normal] System power on by power button.

[Ignition] System power on by ignition pin.

Delay On Timer (Seconds)

The delay time after user trigger ignition on signal (Seconds).

Delay Off Timer (Seconds)

The delay time after user trigger ignition off signal (Seconds).

Force Shutdown Timer (Minutes)

Used to force cut off system power when OS unable gracefully shutdown system successfully.

Voltage Guard

Voltage Guard enable or disable, only effect on Ignition mode.

Voltage Guard Lower limit value

Voltage Guard lower limit value setting. Range: 9v ~ 40v.

Voltage Guard higher limit value

Voltage Guard Higher limit value setting. Range: 15v ~ 55v.

4.5 Security Menu

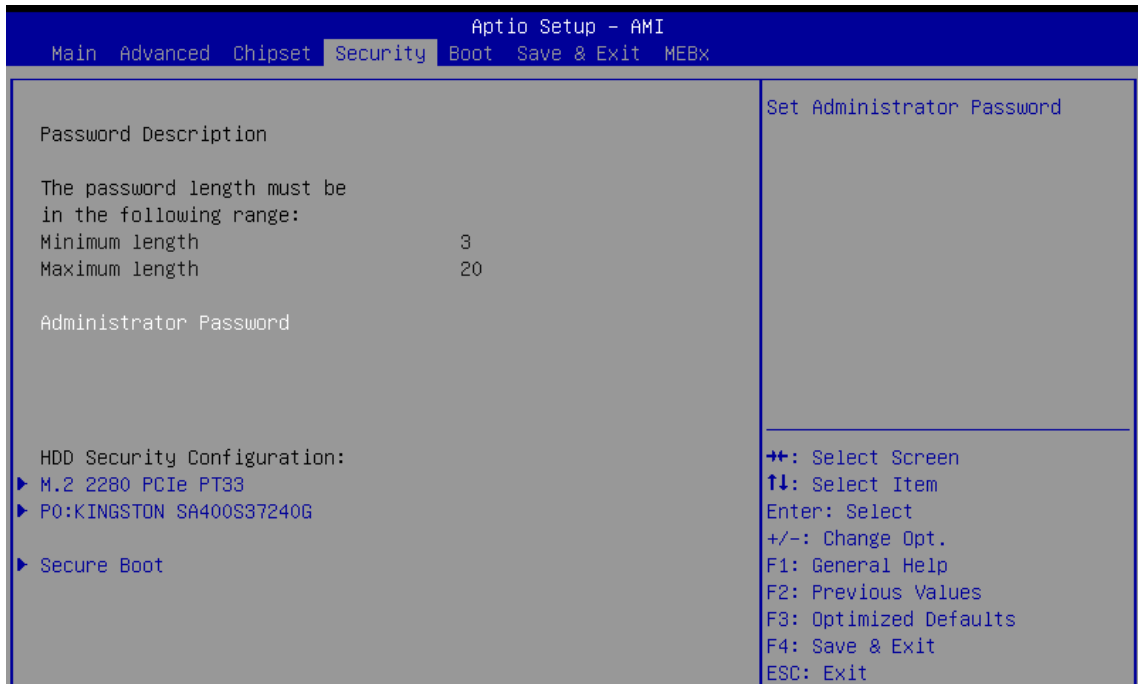

Figure 4-5 : Security Menu

Administrator Password

Set administrator password.

HDD Security Configuration

HDD Security Configuration for selected drive

Secure Boot

Secure Boot configuration

4.6 Boot Menu

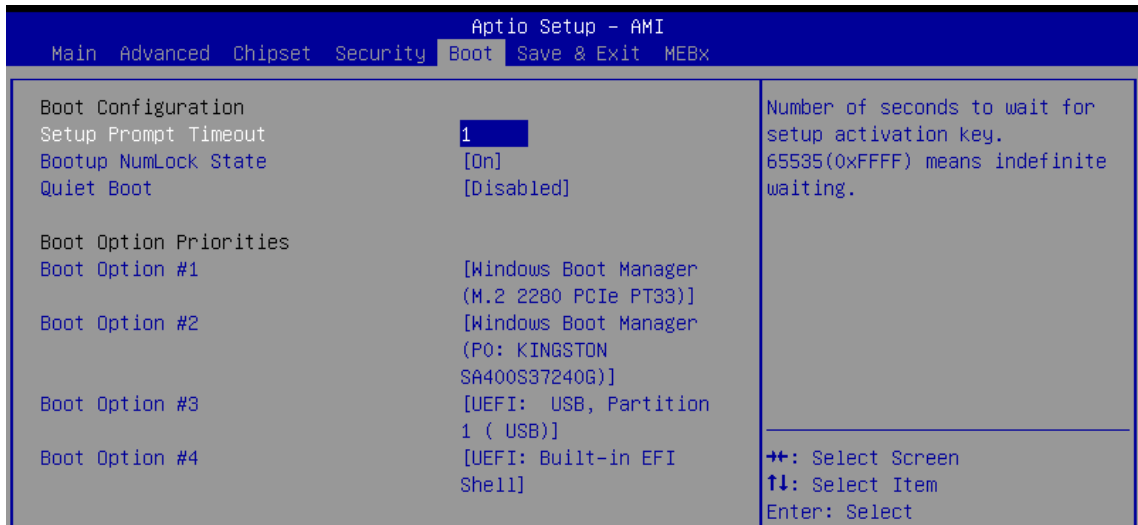

Figure 4-6 : BIOS Boot Menu

Setup Prompt Timeout

Number of seconds to wait for setup activation key. 65535(0xFFFF) means indefinite waiting.

Bootup NumLock State

Select the keyboard NumLock state.

Quiet Boot

Enables or disables Quiet Boot option.

Boot Option Priorities

Sets the system boot order.

4.7 Save & Exit

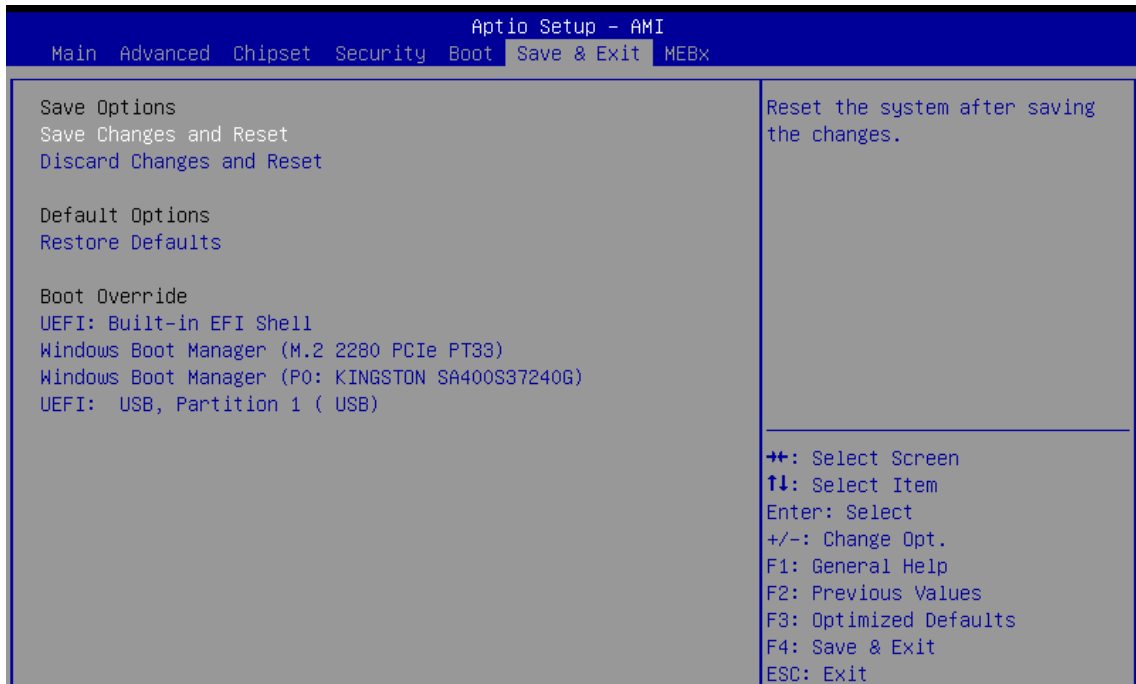

Figure 4-7 : Bios Save and Exit Menu

Save Changes and Reset

Reset the system after saving the changes.

Discard Changes and Reset

Reset system setup without saving any changes.

Restore Defaults

Restore/Load Default values for all the setup options.

A

APPENDIX A : Isolated DIO Guide

A.1 Function Description

The EVS-3000 offers two 16-bit Isolated DIO 20-pin terminal block connector and a watchdog timer.

Isolated DIO pins are fix by Hardware design that cannot change in/out direction in runtime process.

DIO definition is shown below :

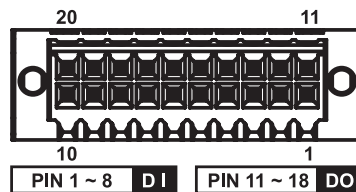

Pin No.	Isolated DIO Definition	Non-Isolated DIO Definition	Pin No.	Isolated DIO Definition	Non-Isolated DIO Definition
1	DI 0	DIO 0	11	DO 0	DIO 8
2	DI 1	DIO 1	12	DO 1	DIO 9
3	DI 2	DIO 2	13	DO 2	DIO 10
4	DI 3	DIO 3	14	DO 3	DIO 11
5	DI 4	DIO 4	15	DO 4	DIO 12
6	DI 5	DIO 5	16	DO 5	DIO 13
7	DI 6	DIO 6	17	DO 6	DIO 14
8	DI 7	DIO 7	18	DO 7	DIO 15
9	DI COM	NC	19	DIO_GND	DIO_GND
10	DIO_GND	DIO_GND	20	External VDC	NC

A.2 Isolated DIO Signal Circuit

DI Reference Circuit :

Sink Mode (NPN)

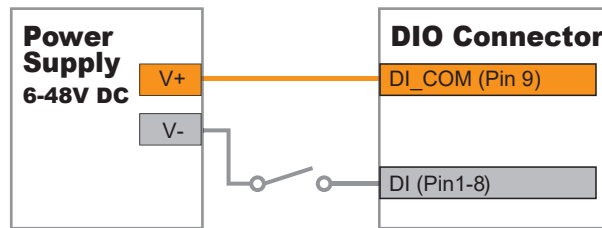

Source Mode (PNP)

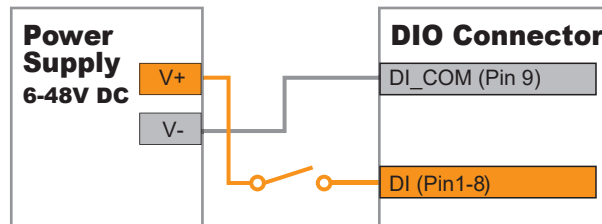

DO Reference Circuit :

Sink Mode
(NPN, Default)

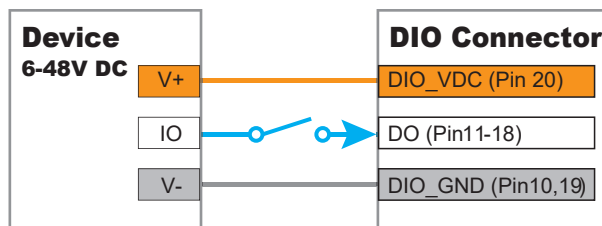

Source Mode
(PNP)

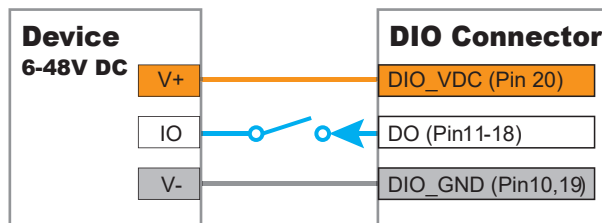

A.3 Isolated DIO Signal Circuit

Distribution folders include x32 and x64 versions, use the batch file for driver installation.

There are included as followed :

Win10_32.bat, and Win10_64.bat :

Installation for driver, and

Uninstall_32.bat, and Uninstall_64.bat :

Uninstallation for driver

Run batch file as Administrator.









Make sure Windows version before installation.

Header folders include head file for software developer or System Integration.

Manual folders include API description.

Sample folders include sample program, driver library, and API library for Windows/Linux

Source folders include sample program source code that compile on Visual Studio 2008/ubuntu16.04.

-  Distribution
-  Header
-  Manual
-  Sample
-  Source
-  Uninstall_32.bat
-  Uninstall_64.bat
-  Win10_32.bat
-  Win10_64.bat

A.4 Sample

Execute demo tool.

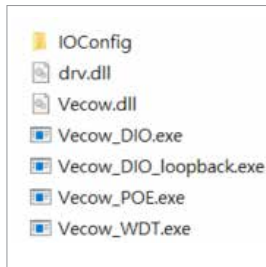

Windows

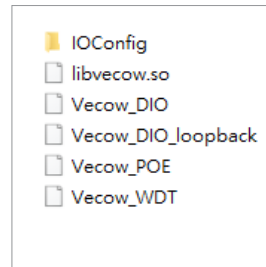

Linux

Sample, as shown below :

```
DIO sample version : v1.0.0609.0608
Load Vecow.dll at least v1.8.1409.0608
Vecow.dll Version : v1.8.1409.0608
Config : IO port I - Isolated DIO
         IO port II - Non-Isolated DIO(GPIO)

Choose IO : (1/2)
```

Vecow_DIO

```
DIO loopback sample version : v1.0.1509.0608
Load Vecow.dll at least v1.8.1409.0608
Vecow.dll Version : v1.8.1409.0608
Config : IO port I - Isolated DIO
         IO port II - Non-Isolated DIO(GPIO)

How many IO temp_port : (1/2)
```

Vecow_DIO_loopback

```
WDT sample version : v1.0.0509.0608
Load Vecow.dll at least v1.8.1409.0608
Vecow.dll Version : v1.8.1409.0608
Config : IO port I - Isolated DIO
         IO port II - Non-Isolated DIO(GPIO)

Set WDT timer seconds (1~3932100) :
```

Vecow_WDT

B

APPENDIX B : Software Functions

B.1 Driver API Guide

In Header folder, Vecow.h and VecowLinux.h contain usable API for Windows/Linux.

BOOL initial_SIO(BYTE Isolate_Type, BYTE DIO_NPN)

Initial machine for IO and watch dogtimer.

Isolate_Type : DIO type.

1 : Isolated DIO;

0 : Non-Isolated DIO(GPIO).

DIO_NPN : DI/DO type.

1 : PNP (Source) mode for European rule;

0 : NPN (Sink) mode for Japanese rule.

Return :

TRUE (1) : Success.

FALSE (0) : Fail (Driver not exists, or version is too old, or machine not match).

BOOL get_IO1_configuration(BYTE *Iso, BYTE *DI_mode, BYTE *DO_mode, WORD *Mask)

BOOL get_IO2_configuration(BYTE *Iso, BYTE *DI_mode, BYTE *DO_mode, WORD *Mask)

Get DIO configuration (by variable)

Isolate_Type : DIO type.

1 : Isolated DIO;

0 : Non-Isolated DIO (GPIO).

DI_mode ([7:0]) : DI type, pin setting by hexadecimal bitmask only for Isolated DIO.

0xFF : PNP (Source) mode for European rule;

0 : NPN (Sink) mode for Japanese rule.

DO_mode : DO type only for Isolated DIO.

1 : PNP (Source) mode for European rule;

0 : NPN (Sink) mode for Japanese rule.

Mask ([15:0]) : In/Out, pin setting by hexadecimal bitmask only for Non-Isolated DIO(GPIO).

1 : Output;

0 : Input

Return :

TRUE (1) : Success.

FALSE (0) : Fail (Initial error, or call by pointer error, or hardware problem).

BOOL set_IO1_configuration(BYTE Iso, BYTE DI_mode, BYTE DO_mode, WORD Mask)

BOOL set_IO2_configuration(BYTE Iso, BYTE DI_mode, BYTE DO_mode, WORD Mask)

Set DIO configuration.

Isolate_Type : DIO type.

1 : Isolated DIO;

0 : Non-Isolated DIO(GPIO).

DI_mode ([7:0]) : DI type, pin setting by hexadecimal bitmask only for Isolated DIO.

0xFF : PNP (Source) mode for European rule;

0 : NPN (Sink) mode for Japanese rule.

DO_mode : DO type only for Isolated DIO.

1 : PNP (Source) mode for European rule;

0 : NPN (Sink) mode for Japanese rule.

Mask ([15:0]) : In/Out, pin setting by hexadecimal bitmask only for Non-Isolated DIO(GPIO).

1 : Output;

0 : Input

Return :

TRUE (1) : Success.

FALSE (0) : Fail (Initial error or hardware problem).

BOOL get_DIO1(BYTE *DO_data, BYTE *DI_data)

BOOL get_DIO2(BYTE *DO_data, BYTE *DI_data)

Get isolated DIO output(DO) and input (DI).

DI ([7:0]) : Input state, pin setting by hexadecimal bitmask.

1 : High;

0 : Low.

DO ([7:0]) : Output state, pin setting by hexadecimal bitmask.

1 : High;

0 : Low.

Return :

TRUE (1) : Success.

FALSE (0) : Fail (Initial error or hardware problem).

FALSE (0) : Fail (Initial error or hardware problem).

BOOL set_DIO1(BYTE DO_data)

BOOL set_DIO2(BYTE DO_data)

Set isolated DIO output(DO).

DO ([7:0]) : Output state, pin setting by hexadecimal bitmask.

1 : High;

0 : Low.

Return :

TRUE (1) : Success.

FALSE (0) : Fail (Initial error or hardware problem).

FALSE (0) : Fail (Initial error or hardware problem).

BOOL get_GPIO1(WORD *GPIO_data)

Get GPIO.

GPIO_data ([15:0]) : GPIO state, pin setting by hexadecimal bitmask.
1 : High;
0 : Low.

Return :

TRUE (1) : Success.
FALSE (0) : Fail (Initial error or hardware problem).

BOOL set_GPIO1(WORD GPIO_data)

Set GPIO.

GPIO_data ([15:0]) : GPIO state, pin setting by hexadecimal bitmask.
1 : High;
0 : Low.

Return :

TRUE (1) : Success.
FALSE (0) : Fail (Initial error or hardware problem).

BOOL get_WDT(DWORD *WDT)

Get watchdog timer setup.

WDT : watchdog timer setup.

Unit : second (Range : 0 ~ 65535 sec, 1093 ~ 65535 min (=65580 ~ 3932100 sec)).

Return :

TRUE (1) : Success.
FALSE (0) : Fail (Initial error, or call by pointer error, or hardware problem).

BOOL set_WDT(DWORD WDT)

Set watchdog timer setup.

WDT : watchdog timer setup.

Unit : second (Range : 0 ~ 65535 sec, 1093 ~ 65535 min (=65580 ~ 3932100 sec)).

Return :

TRUE (1) : Success.
FALSE (0) : Fail (Initial error, or setup 0, or hardware problem).

BOOL cancel_WDT()

Cancel watchdog timer.

Return :

TRUE (1) : Success.
FALSE (0) : Fail (Initial error or hardware problem).
FALSE (0): Fail (Driver not exists, or version is too old, or out of range error).

C

APPENDIX C : RAID Functions

C.1.1 VMD Mode for RAID

Please set Enable VMD controller as Enabled on BIOS menu.

Chipset → System Agent (SA) Configuration → VMD setup menu → Enable VMD controller → Enabled → Save Changes and Reset.

1. Select System Agent (SA) Configuration.

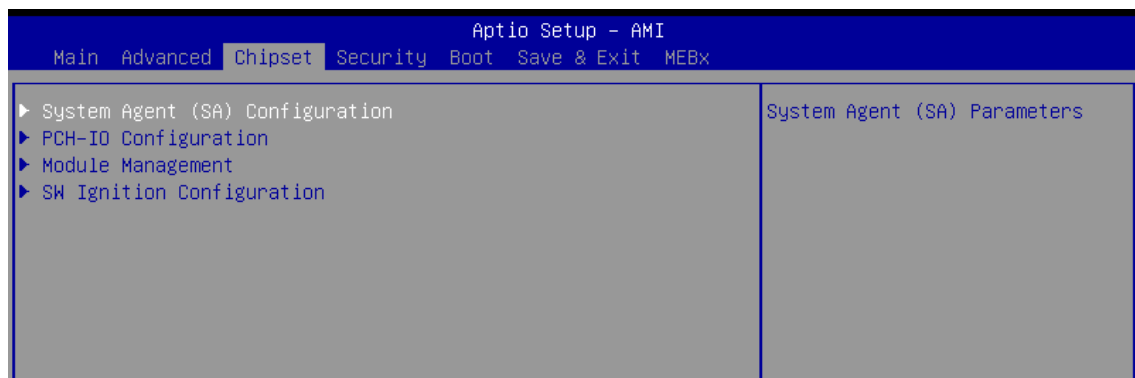

2. Select VMD setup menu.

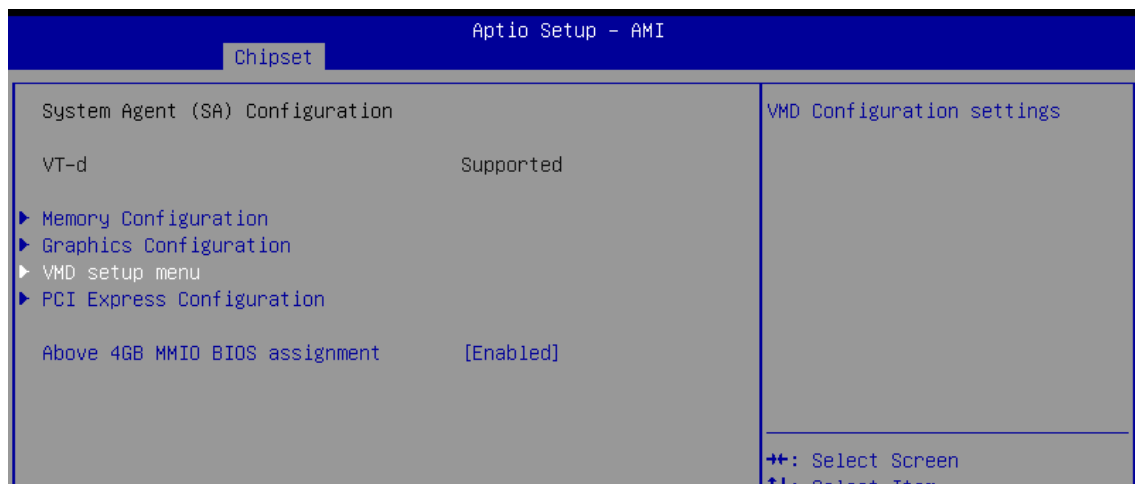

3. Enabled VMD controller. Then Save Changes and Reset.

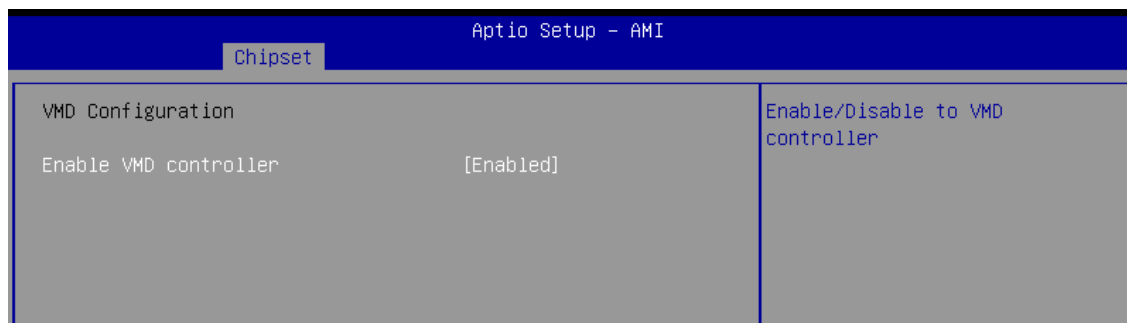

C.1.2 UEFI Mode for RAID

1. Into BIOS menu again, select Intel(R) Rapid Storage Technology on BIOS menu. Advanced → Intel(R) Rapid Storage Technology

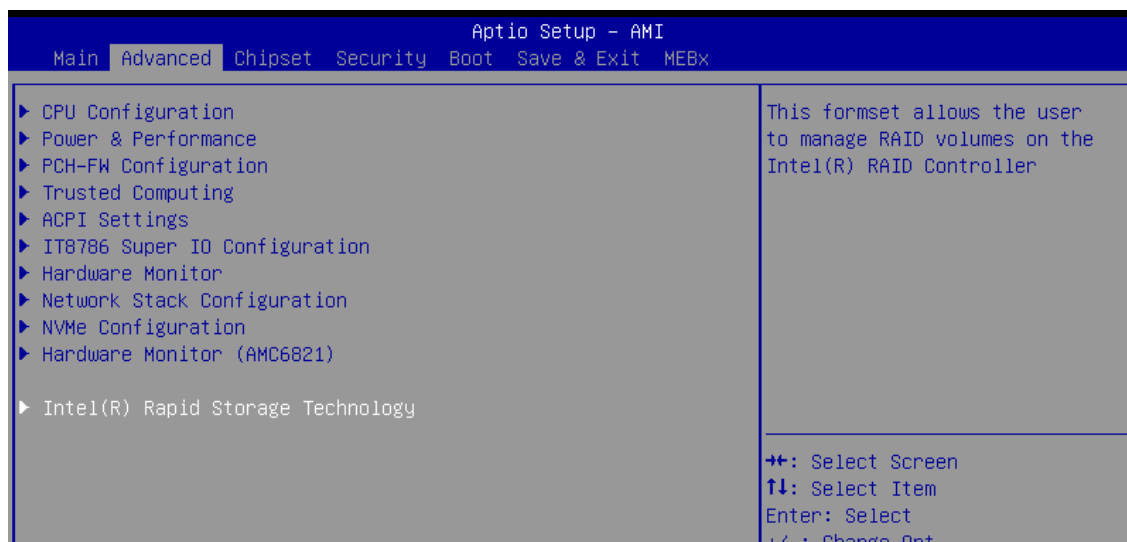

2. Select Create RAID Volume on BIOS menu.

This system is featured 2 M.2 Key M for NVMe SSD, and 4 SATA slots for HDD. Please note. Storage device M.2 and SATA cannot be mixed to create a RAID Volume.

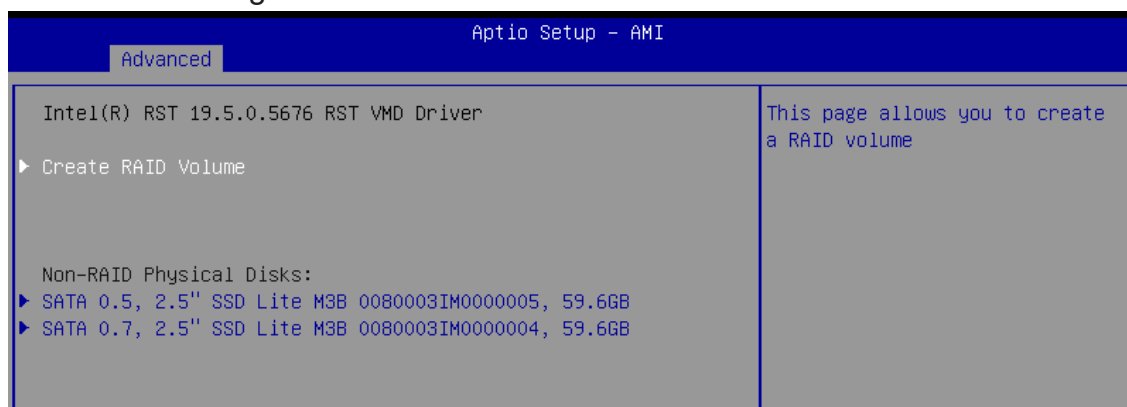

3. Select disks to create RAID Volume, then Save Changes and Reset to install OS.

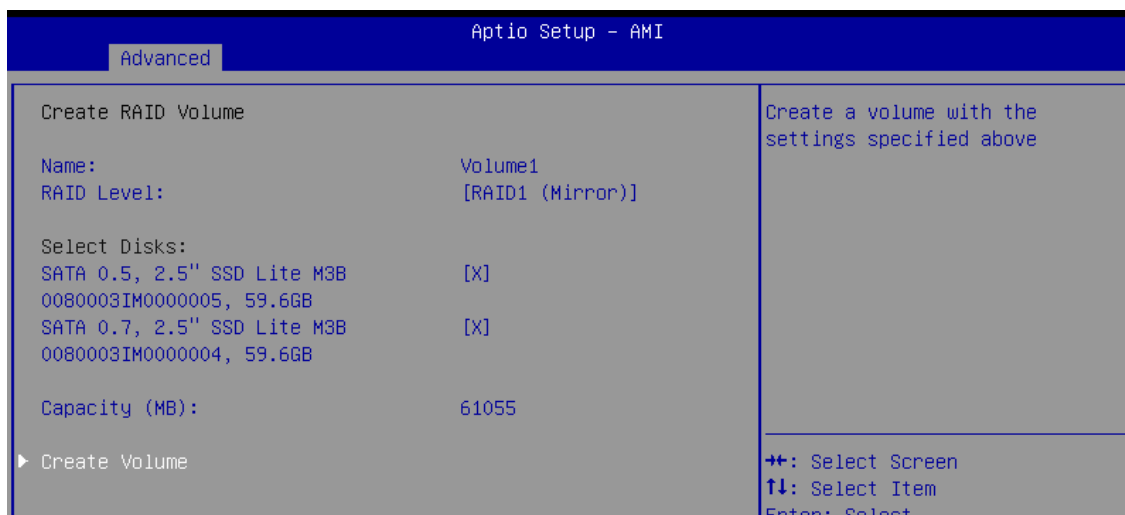

C.2 OS Installation

The system is featured with 2 Front-access 2.5" SSD/HDD Tray and 2 Front-access M.2 Key M SSD Tray (The M.2 Key M SSD Tray is only available on the ECX-3300 and ECX3400)

We used SATA for Windows 10 OS installation as an example.

C.3 To Install All Device Drivers of the System

The instructions are as follows :

1. Install Chipset driver
2. Install Network driver
3. Install ME driver (if available)
4. Install Audio driver
5. Install VGA driver

C.4 To Install "Intel Rapid Storage Technology" Software

You can get the latest information and the software directly from Intel website.

http://www.intel.com/p/en_US/support/highlights/chpsts/imsm

The RAID environment has been done if you completed the steps above.

C.5 To Insert SATA HDD for RAID 1

Please note, you can use two SATA ports for SATA HDD, except for mSATA slot.

C.6 To Create RAID Volume on "Rapid Storage Technology" Software

The system is featured with two SATA HDD's for RAID volume, so there are two options to choose on this page. Let's take RAID 1 as an example, select "RAID 1".



C.7 Disk Management : Partition the Disk

After RAID 1 volume is created, you can see the figure of SATA device allocation.

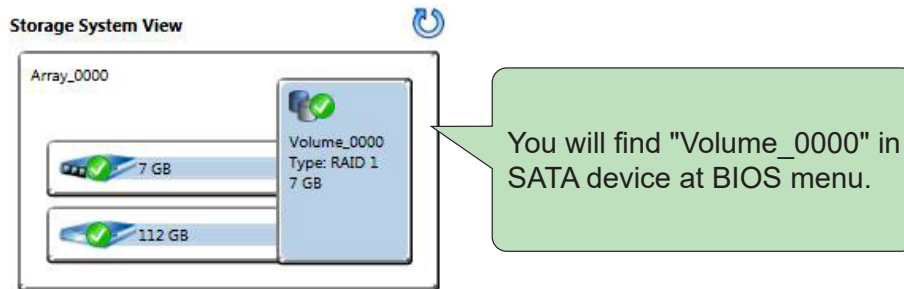

To start disk management tool, select "initialize disk".

Then add "Logical Device" for Windows access.

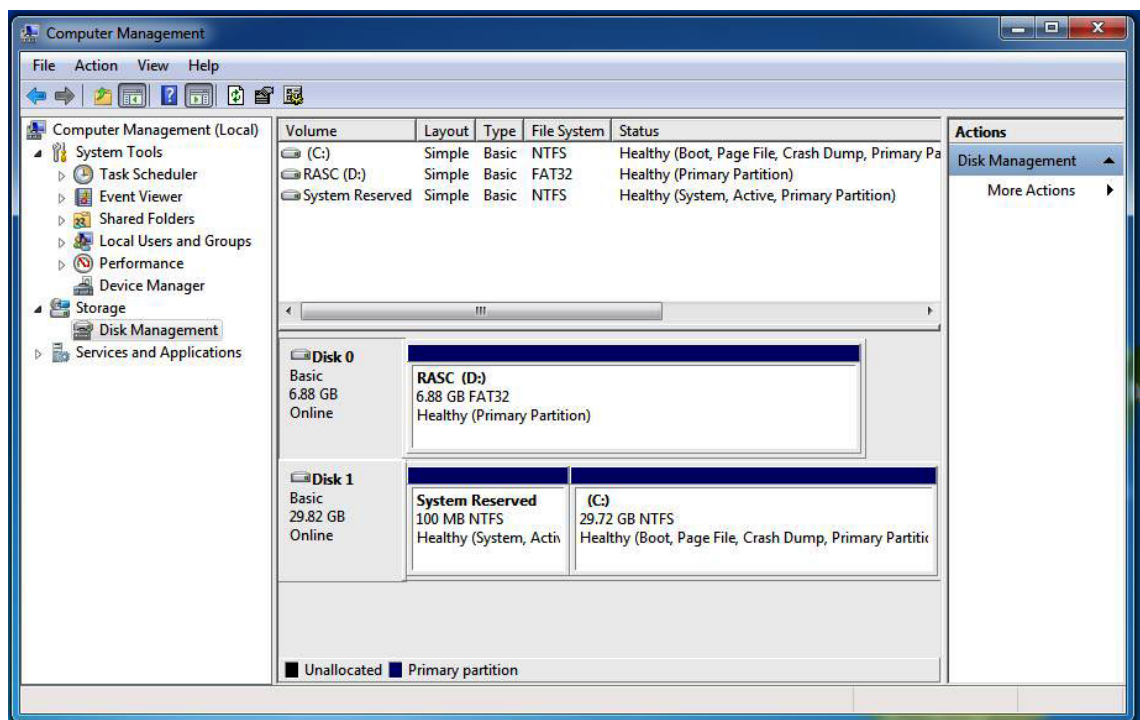

C.8 If One SATA HDD on RAID Volume is Out-of-use

After RAID 1 volume is created, you can see the figure of SATA device allocation.

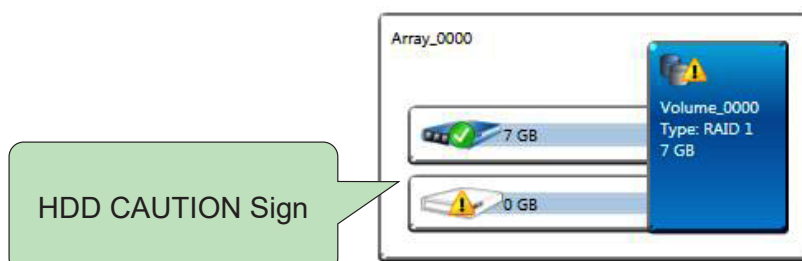

C.9 Recovery and Auto Re-build When Using the SAME RAID HDD

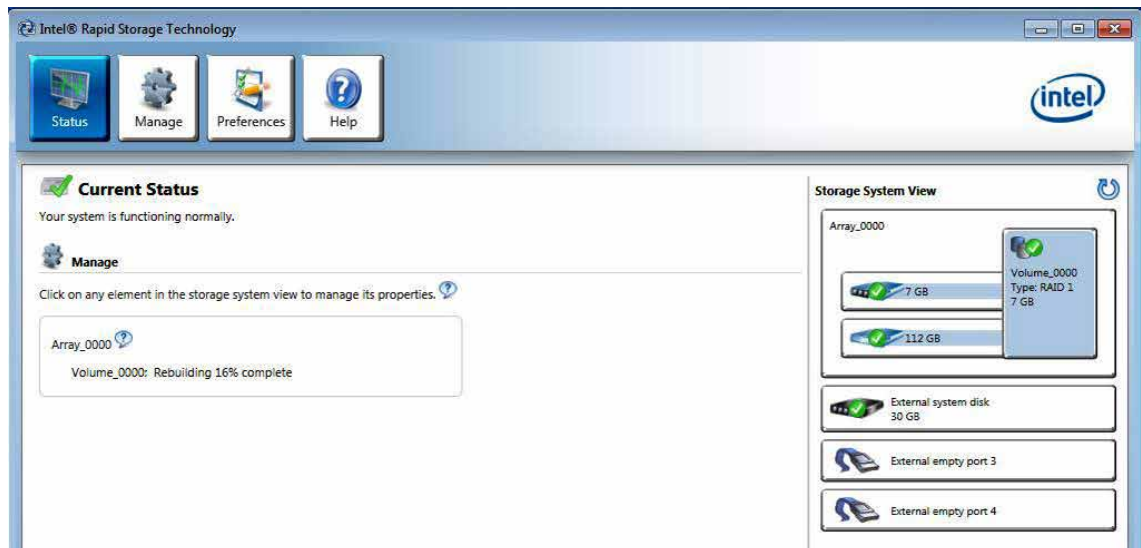

C.10 Recovery and Auto Re-build When Using DIFFERENT RAID HDD

A warning will pop-up to ask you if the disk is not a member of the original RAID volume.

If you press "Rebuild", it will replace the broken SATA HDD to the last SATA HDD of RAID volume.

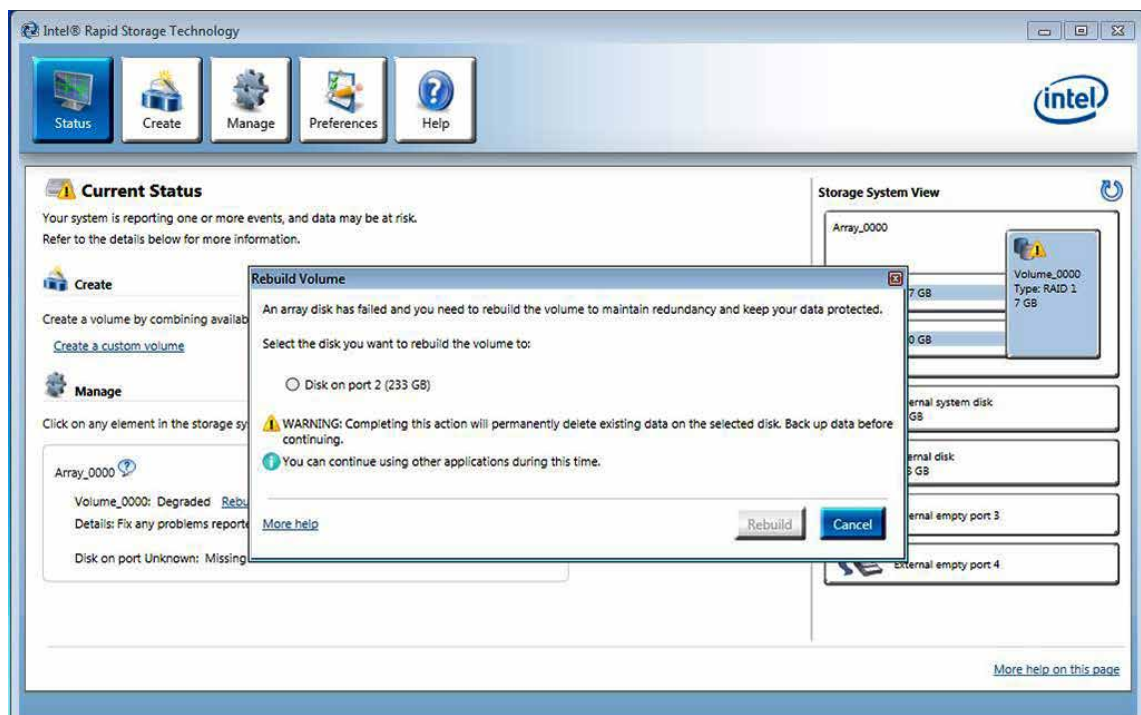

D

APPENDIX D : Power Consumption

Testing Board	EVS-3000
RAM	16GB * 2
USB-1 : (USB 3.0)	USB logitech Keyboard K120
USB-2 : (USB 3.0)	USB logitech Mouse K120
SATA 0	Innodisk 3TG8-P 8TB
Graphics output	DP
Power plan	Balance(Windows10 Power plan)
Power Source :	Chroma 62006P-100-25
Test Program-1	BurnInTest v10.2
Test Program-2	FurMark v2.4.3.0(1920x1200, 8X MSAA)
Test Program-3	CPU-Z v2.09

D.1 Intel® Core™ i7-13700TE (30M Cache, 4.80 GHz)

Power on and boot to Win 10 (64-bit)

CPU	Power Input	Standby Mode		Power on and boot to Win 10 (64-bit)			
				Sleep Mode		Idle status CPU usage less 3%	
		Max Current	Max Consumption	Max Current	Max Consumption	Max Current	Max Consumption
i7-13700TE	09V	0.572A	05.14W	0.671A	06.04W	2.557A	23.01W
i7-13700TE	12V	0.434A	05.19W	0.511A	06.14W	2.351A	28.21W
i7-13700TE	24V	0.267A	06.39W	0.307A	07.37W	1.221A	29.30W
i7-13700TE	55V	0.177A	09.73W	0.196A	10.78W	0.654A	35.97W

CPU	Power Input	Power on and boot to Win 10 (64-bit)			
		Run 100% CPU usage without 3D		Run 100% CPU usage with Furmark	
		Max Current	Max Consumption	Max Current	Max Consumption
i7-13700TE	09V	5.125A	46.12W	6.439A	57.95W
i7-13700TE	12V	3.856A	46.28W	5.482A	65.78W
i7-13700TE	24V	2.014A	48.33W	2.852A	68.44W
i7-13700TE	55V	1.023A	56.26W	1.409A	77.49W

D.2 Intel® Core™ i7-13700E (30M Cache, 5.10 GHz)

Power on and boot to Win 10 (64-bit)

CPU	Power Input	Standby Mode		Power on and boot to Win 10 (64-bit)			
				Sleep Mode		Idle status CPU usage less 3%	
		Max Current	Max Consumption	Max Current	Max Consumption	Max Current	Max Consumption
i7-13700E	09V	0.576A	05.17W	0.684A	06.15W	2.229A	20.07W
i7-13700E	12V	0.433A	05.19W	0.518A	06.21W	1.872A	22.46W
i7-13700E	24V	0.266A	06.38W	0.309A	07.43W	1.215A	29.16W
i7-13700E	55V	0.178A	09.76W	0.198A	10.87W	0.597A	32.83W

CPU	Power Input	Power on and boot to Win 10 (64-bit)			
		Run 100% CPU usage without 3D		Run 100% CPU usage with Furmark	
		Max Current	Max Consumption	Max Current	Max Consumption
i7-13700E	09V	7.058A	63.51W	10.071A	90.63W
i7-13700E	12V	5.308A	63.96W	7.773A	93.27W
i7-13700E	24V	2.760A	66.24W	4.139A	99.33W
i7-13700E	55V	1.469A	80.79W	1.919A	105.54W

D.3 Intel® Core™ i7-13700E (30M Cache, 5.10 GHz) with MXM T1000

Power on and boot to Win 10 (64-bit)

CPU	Power Input	Standby Mode		Power on and boot to Win 10 (64-bit)			
				Sleep Mode		Idle status CPU usage less 3%	
		Max Current	Max Consumption	Max Current	Max Consumption	Max Current	Max Consumption
i7-13700E	9V	0.571A	05.14W	0.661A	05.95W	2.261A	20.34W
i7-13700E	12V	0.439A	05.29W	0.527A	06.33W	1.772A	21.27W
i7-13700E	24V	0.265A	06.38W	0.306A	07.36W	1.360A	36.60W
i7-13700E	55V	0.177A	09.77W	0.197A	10.87W	0.785A	43.14W

CPU	Power Input	Power on and boot to Win 10 (64-bit)			
		Run 100% CPU usage without 3D		Run 100% CPU usage with Furmark	
		Max Current	Max Consumption	Max Current	Max Consumption
i7-13700E	9V	9.174A	82.56W	15.892A	143.02W
i7-13700E	12V	7.118A	85.41W	12.006A	144.07W
i7-13700E	24V	3.712A	89.09W	6.016A	144.36W
i7-13700E	55V	2.959A	107.77W	2.772A	152.50W

D.4 Intel® Core™ i7-13700E (30M Cache, 5.10 GHz) with MXM RTX5000

Power on and boot to Win 10 (64-bit)

CPU	Power Input	Standby Mode		Power on and boot to Win 10 (64-bit)			
				Sleep Mode		Idle status CPU usage less 3%	
		Max Current	Max Consumption	Max Current	Max Consumption	Max Current	Max Consumption
i7-13700E	9V	0.569A	05.11W	0.681A	06.12W	4.147A	37.32W
i7-13700E	12V	0.432A	05.19W	0.520A	06.24W	3.253A	39.03W
i7-13700E	24V	0.267A	06.38W	0.311A	07.47W	1.741A	41.78W
i7-13700E	55V	0.178A	09.78W	0.197A	10.84W	0.875A	48.12W

CPU	Power Input	Power on and boot to Win 10 (64-bit)			
		Run 100% CPU usage without 3D		Run 100% CPU usage with Furmark	
		Max Current	Max Consumption	Max Current	Max Consumption
i7-13700E	9V	11.224A	101.01W	19.723A	177.50W
i7-13700E	12V	9.306A	111.67W	14.902A	178.82W
i7-13700E	24V	4.892A	117.40W	7.513A	180.31W
i7-13700E	55V	2.205A	121.27W	3.327A	182.98W

D.5 Intel® Core™ i7-13700E (30M Cache, 5.10 GHz) with MXM A2000

Power on and boot to Win 10 (64-bit)

CPU	Power Input	Standby Mode		Power on and boot to Win 10 (64-bit)			
				Sleep Mode		Idle status CPU usage less 3%	
		Max Current	Max Consumption	Max Current	Max Consumption	Max Current	Max Consumption
i7-13700E	9V	0.568A	05.11W	0.678A	06.09W	3.909A	35.18W
i7-13700E	12V	0.431A	05.17W	0.517A	06.20W	3.072A	36.86W
i7-13700E	24V	0.267A	06.39W	0.309A	07.41W	1.665A	39.96W
i7-13700E	55V	0.178A	09.78W	0.197A	10.86W	0.833A	45.81W

CPU	Power Input	Power on and boot to Win 10 (64-bit)			
		Run 100% CPU usage without 3D		Run 100% CPU usage with Furmark	
		Max Current	Max Consumption	Max Current	Max Consumption
i7-13700E	9V	8.460A	67.68W	10.251A	92.25W
i7-13700E	12V	6.103A	73.23W	7.701A	92.41W
i7-13700E	24V	3.347A	80.32W	4.042A	97.00W
i7-13700E	55V	1.716A	94.38W	1.993A	109.61W

D.6 Intel® Core™ i7-13700E (30M Cache, 5.10 GHz) with MXM A4500

Power on and boot to Win 10 (64-bit)

CPU	Power Input	Standby Mode		Power on and boot to Win 10 (64-bit)			
				Sleep Mode		Idle status CPU usage less 3%	
		Max Current	Max Consumption	Max Current	Max Consumption	Max Current	Max Consumption
i7-13700E	9V	0.570A	05.11W	0.679A	06.10W	3.645A	32.80W
i7-13700E	12V	0.433A	05.18W	0.517A	06.20W	2.829A	33.94W
i7-13700E	24V	0.266A	06.37W	0.310A	07.43W	1.662A	39.88W
i7-13700E	55V	0.177A	09.74W	0.197A	10.84W	0.834A	45.87W

CPU	Power Input	Power on and boot to Win 10 (64-bit)			
		Run 100% CPU usage without 3D		Run 100% CPU usage with Furmark	
		Max Current	Max Consumption	Max Current	Max Consumption
i7-13700E	9V	9.355A	84.19W	19.870A	178.83W
i7-13700E	12V	7.151A	85.81W	15.173A	182.07W
i7-13700E	24V	3.777A	90.64W	7.837A	188.08W
i7-13700E	55V	2.047A	112.58W	3.631A	199.70W

D.7 Intel® Core™ i7-13700E (30M Cache, 5.10 GHz) with MXM A2000 Ada

Power on and boot to Win 10 (64-bit)

CPU	Power Input	Standby Mode		Power on and boot to Win 10 (64-bit)			
				Sleep Mode		Idle status CPU usage less 3%	
		Max Current	Max Consumption	Max Current	Max Consumption	Max Current	Max Consumption
i7-13700E	9V	0.558A	05.02W	0.657A	05.92W	3.268A	29.41W
i7-13700E	12V	0.432A	05.17W	0.498A	05.97W	2.567A	30.80W
i7-13700E	24V	0.266A	06.39W	0.308A	07.39W	1.364A	32.73W
i7-13700E	55V	0.178A	09.78W	0.198A	10.87W	0.819A	45.04W

CPU	Power Input	Power on and boot to Win 10 (64-bit)			
		Run 100% CPU usage without 3D		Run 100% CPU usage with Furmark	
		Max Current	Max Consumption	Max Current	Max Consumption
i7-13700E	9V	9.041A	81.36W	13.496A	121.46W
i7-13700E	12V	6.855A	82.26W	10.181A	122.17W
i7-13700E	24V	3.671A	88.10W	5.296A	127.10W
i7-13700E	55V	1.830A	100.65W	2.492A	137.06W

E

APPENDIX E : Supported Memory & Storage List

E.1 Supported Memory List

Testing Board	EVS-3000
Memory Test	MemTest86 V11.0
BurnInTest	BurnInTest Pro V10.2 (build 1011)

E.2 Test Item

Channel	Memory Test	OS internal info	Hibernate	Reboot
*1(DIMM 1)	PASS	PASS	PASS	PASS
*1(DIMM 2)	PASS	PASS	PASS	PASS

E.3 ECC

Brand	Info	Test Temp. (Celsius)
Team Group DDR5-5600 48GB SODIMM	TE48GFSEV2TH-V	25
Innodisk DDR5-5600 16GB SODIMM	M5D0-AGS2PCZQ	25
Transcend DDR5-5600 32GB SODIMM	TS4GSA72V6E	25
Kingston DDR5-5600 32GB SODIMM	9965802-021.A00G	25

E.4 NON-ECC

Brand	Info	Test Temp. (Celsius)
Transcend 8G DDR5-5600 SO-DIMM	TS1GSA64V6G	25
Samsung 16G DDR5-5600 SO-DIMM	M425RGA3PB0-CWM0D	25
Innodisk 32G DDR5-5600 SO-DIMM	M5S0-BG2OCZQ-H03	25

E.5 Supported Storage Device List

Type	Brand	Model	Capacity
SATA SSD	Innodisk	DGS25-08TDE1KWAEFP/3TG8-P	8TB
	Innodisk	DES25-C12DK1KCCQL-H03/3TE7	512GB
	Transcend	TS512GSSD460K	512GB
M.2 M Key NVMe	Samsung	Samsung 980 Pro	256GB
	Transcend	TS512GMTE720T	512GB
	Innodisk	DGM28-C120P1KCAEF-H03/4TG2-P	512GB
	Innodisk	DEM28-C12DD1KCCQF-H03 G3X2/3TE6	512GB
M.2 B Key NVMe	Innodisk	DEM28-C12DD1KCCQF-H03 G3X2/3TE6	512GB
	Transcend	TS512GMTE460T	512GB
M.2 B Key SATA	Innodisk	DEM28-C12DK1KCAQL-H03/3TE7	512GB
	SMART	AFBCK1125600006	256GB

F

APPENDIX F : Setting up Allxon OOB

1. Setting up Allxon OOB

This section will guide you step-by-step on how to enable and activate OOB Management Services. If you need to use both services (Allxon INB and OOB features), please follow the steps below.

1.1 Enable Allxon INB & OOB Services

1.1.1 Install Allxon Agent on Device

Users can easily initiate the Allxon Agent installation process from their desktop using selected devices from Allxon's hardware partners.

Refer to the following webpage for detailed instructions:

[Install Allxon Agent via Command Prompt](#)

1.1.2 Pairing Edge Device to Allxon Portal

- Get Device Pairing Code

Refer to the following webpage for detailed instructions:

[Get Device Pairing Code](#)

- Get Add Your Device on Allxon Portal

Refer to the following webpage for detailed instructions:

[Add Your Device on Allxon Portal](#)

1.1.3 Enable OOB Enabler on Device

After you have paired and added your device onto Allxon Portal, you will now have the option to also link the OOB Enabler to Allxon Portal.

Refer to the webpage for detailed instructions:

[Enable Out-Of-Band Management on Device](#)

1.2 Allxon swiftDR for Power Cycling

Allxon swiftDR Series is a powerful Out-Of-Band remote device management solution to empower disaster recovery. This section details Allxon swiftDR for Power Cycling on Allxon Portal, to introduce Allxon's power-related OOB features.

Refer to the webpage for detailed instructions:

[Allxon swiftDR for Power Cycling](#)

2. Troubleshooting Your OOB Enabler

2.1 Network Connectivity Requirements

To get the best out of Allxon Services, ensure you are connected to a stable Internet connection. If your organization restricts Internet communications with the network using a firewall or proxy device, refer to the following webpage for detailed Information:

[Allxon Service Port/Protocol and Whitelist Information](#)

** If more help is needed, please contact Vecow Technical Support.**



For further support information, please visit www.vecow.com

This document is released for reference purpose only.

All product offerings and specifications are subject to change without prior notice.

No part of this publication may be reproduced in any form or by any means, electric, photocopying, or recording, without prior authorization from the publisher.

The rights of all the brand names, product names, and trademarks belong to their respective owners.

© Vecow Co., Ltd. 2024. All rights reserved.